

USE WITH FOLLOWING KILN ASSEMBLIES:

MODEL	WIRING DIAGRAM
JD18	K028-111
JD18X	K032-111
JD23	K035-112
JD230	K037-114
JD230S	K037-116
JD2918	K043-112
JD2927	K043-113

SEE KILN WIRING DIAGRAM

PLUG KILN SECTION CAPS INTO RESPECTIVE RECEPTACLES

NOTES:

Control Wire:
14 AWG, SEWF, 105°C

Power Wire:
14 AWG, SEWF, 105°C

Industrial & commercial applications may require the installation of a LOCKOUT/TAGOUT device to prevent the Kiln from operating during maintenance.

This Kiln is recommended to be wired & connected to an approved U. L. & NEC configured disconnect switch and properly fused according to the KW load load specification listed on the Kiln Nameplate. L&L Kiln Mfg., Inc., also recommends fuses rather than circuit breakers to prevent nuisance tripping.

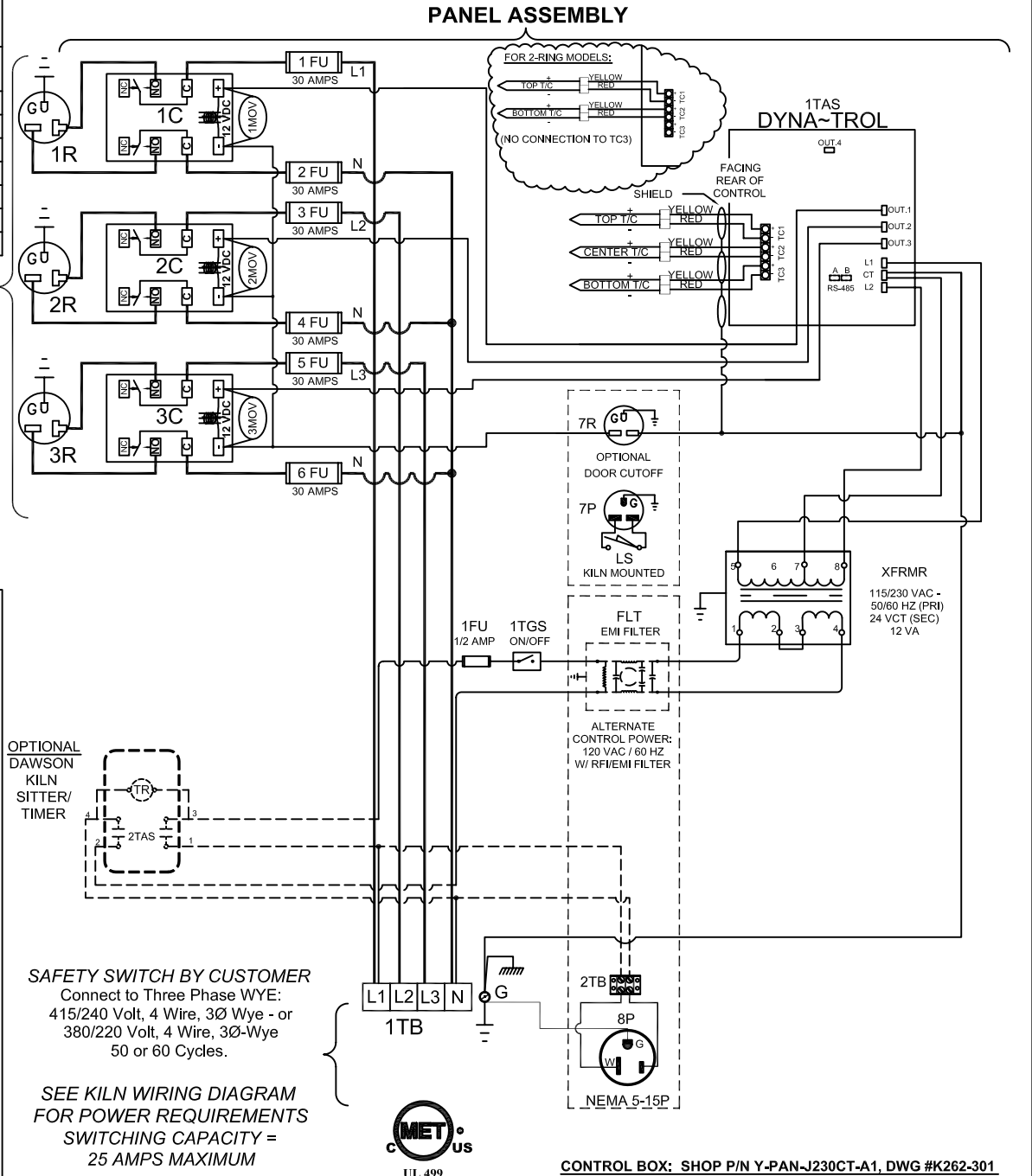

ELECTRICAL PARTS LIST				
SYMBOL	QTY	DESCRIPTION	SHOP PART NO.	CUSTOMER PART NO.
1TB	1	POWER CONNECTION BOARD	E-TER-3X6175-A1	L-J-PBLG/02
1TAS	1	BARTLETT DYNATROL	T-CPC-DYNA3Z-A1	N-G-D300/00
T/C.	3	THERMOCOUPLES (8 Ga)	J-TCL-K0803C-A1	T-G-E800/00
C	3	POWER RELAYS	E-CNT-EO252Y-A1	L-G-RL25/12
FU(B)	3	ELEMENT BRANCH CIRCU FUSEBLOCKS	E-FUB-H20302-A1	L-G-FH30/20
FU(S)	6	ELEMENT BRANCH CIRCUIT FUSES	E-FUS-NN2030-A1	L-G-FS30/NL
1-3MOV	3	31 VOLT SURGE SUPPRESSORS	E-SUG-V39ZA1-A1	L-G-MOV0/00
1FU	1	CONTROL FUSE	E-FUS-AGC2F5-A1	L-C-FS05/00
1FUB	1	PANEL MOUNT FUSE HOLDER	E-FUB-P20101-A1	L-G-FSPB/00
1TGS	1	ON/OFF TOGGLE SWITCH	E-SWT-XN1003-A1	L-G-SWTG/00
XFRMR	1	STEP DOWN TRANSFORMER	E-TRD-212VAS-A1	L-G-TR24/OO
R	3	SINGLE RECEPTACLE NEMA 6-20R	E-REC-S20250-A1	L-J-SR20/00
2TAS	1 (OPT)	DAWSON KILN SITTER	T-DAW-LT3240-A1	N-G-LT30/00
2TAS	1 (OPT)	50 HZDAWSON KILN SITTER	T-DAW-LT3240-A2	N-G-LT30/50
OPTIONAL KEYSWITCH & DOOR CUTOFF:				
LS	1 (OPT)	LONG ARM LIMIT SWITCH	E-LIM-BL29SX-A1	L-G-SWLM/00
7R	1 (OPT)	MINIATURE 12 V RECEPTACLE	E-REC-207300-A1	L-G-LCAP/00
7P	1 (OPT)	MINIATURE 12 V PLUG	E-PLG-207300-A1	L-G-LPLG/00
1KS	1 (OPT)	ON/OFF KEYSWITCH (REPLACE 1TGS)	E-SWK-XN2002-A1	L-S-KS00/00
ALTERNATE CONTROL POWER SUPPLY:				
2TB	1	2-POST TERMINAL BOARD	E-TER-2X6115-A1	L-J-PB00/01
FLT	1	EMI FILTER	E-RCT-FILTER-A1	L-G-RFFT/00
8P	1	72" CONTROL PWR PLUG, NEMA 5-15P	E-CRD-172015-B1	L-G-PC15/10

Kilns
hotkilns.com

505 SHARPTOWN ROAD
SWEDESBORO, NJ 08085

PHONE: (856) 294-0077
FAX: (856) 294-0070

CONTROL WIRING DIAGRAM
WITH PANEL MOUNTED DYNA-TROL

For 3 Phase KILN with (3) 20 Amp Sections
Branch Circuit Fusing / No Power Bottom

DRAWN BY: **G.D.L** REV. CODE: **A** DRAWING NO. **K262-167**

DATE: 5/30/02 SCALE: 1 = 8

CHK: G.D.L. APP: SHEET NO. | OF |

FILE NAME: L:\E\ILLKILN\WRDGC\T\K262-167.dwg MADE FROM: K262-154.dwg