

SINGLE PHASE MODELS:

| MODELS T3436-PB & T3436-D-PB | | |
|------------------------------|-----------------|-----------|
| VOLTAGE | 208 / 1 / 50-60 | |
| KW | 38.8 | |
| FULL LOAD AMPS | L1 | L2 L3 |
| | 186.5 | 186.5 X |
| POWER SUPPLY | FUSE | WIRE |
| | 225A | 350 MCM |
| ELEMENTS (E-T-3400/20) | QTY | OHMS |
| | 14 | 15.6 |
| VOLTAGE | 220 / 1 / 50-60 | |
| KW | 38.8 | |
| FULL LOAD AMPS | L1 | L2 L3 |
| | 176.3 | 176.3 X |
| POWER SUPPLY | FUSE | WIRE |
| | 225A | 350 MCM |
| ELEMENTS (E-T-3400/40) | QTY | OHMS |
| | 14 | 17.5 |
| VOLTAGE | 240 / 1 / 50-60 | |
| KW | 38.8 | |
| FULL LOAD AMPS | L1 | L2 L3 |
| | 161.6 | 161.6 X |
| POWER SUPPLY | FUSE | WIRE |
| | 200A | 250 MCM |
| ELEMENTS (E-T-3400/30) | QTY | OHMS |
| | 14 | 20.8 |

THREE PHASE MODELS:

| MODELS T3436-PB & T3436-D-PB | | |
|------------------------------|-----------------|--------------|
| VOLTAGE | 208 / 3 / 50-60 | |
| KW | 38.8 | |
| FULL LOAD AMPS | L1 | L2 L3 |
| | 126.9 | 103.8 92.3 |
| POWER SUPPLY | FUSE | WIRE |
| | 150A | 2/0 AWG |
| ELEMENTS (E-T-3400/20) | QTY | OHMS |
| | 14 | 15.6 |
| VOLTAGE | 220 / 3 / 50-60 | |
| KW | 38.8 | |
| FULL LOAD AMPS | L1 | L2 L3 |
| | 120.0 | 98.2 87.3 |
| POWER SUPPLY | FUSE | WIRE |
| | 150A | 2/0 AWG |
| ELEMENTS (E-T-3400/40) | QTY | OHMS |
| | 14 | 17.5 |
| VOLTAGE | 240 / 3 / 50-60 | |
| KW | 38.8 | |
| FULL LOAD AMPS | L1 | L2 L3 |
| | 110.0 | 90.0 80.0 |
| POWER SUPPLY | FUSE | WIRE |
| | 150A | 2/0 AWG |
| ELEMENTS (E-T-3400/30) | QTY | OHMS |
| | 14 | 20.8 |

1 PHASE CONTROL PANELS:

| MODEL | (AUTO/MANUAL) | WIRING DIAGRAM |
|------------|---------------|----------------|
| T3436-PB | (MANUAL) | K265-105 |
| T3436-D-PB | (AUTO) | K265-155 |

3 PHASE CONTROL PANELS:

| MODEL | (AUTO/MANUAL) | WIRING DIAGRAM |
|------------|---------------|----------------|
| T3436-PB | (MANUAL) | K265-106 |
| T3436-D-PB | (AUTO) | K265-156 |



SEE CONTROL PANEL WIRING DIAGRAM FOR WIRING CONNECTIONS TO KILN ZONE RECEPTACLES

NOTES:

Industrial & commercial applications may require the installation of a LOCKOUT/TAGOUT device to prevent the Kiln from operating during maintenance.

This Kiln is recommended to be wired & connected to an approved U. L. & NEC configured disconnect switch and properly fused according to the KW load specification listed on the Kiln Nameplate. L&L Kiln Mfg., Inc., also recommends fuses rather than circuit breakers to prevent nuisance tripping.

ELECTRICAL PARTS LIST

| SYMBOL | QTY | DESCRIPTION | CUSTOMER PART NO. |
|--------|-----|----------------------|-------------------|
| P | 5 | 72" PLUGS NEMA 6-50P | L-G-PC50/72 |

KILN ASSEMBLY

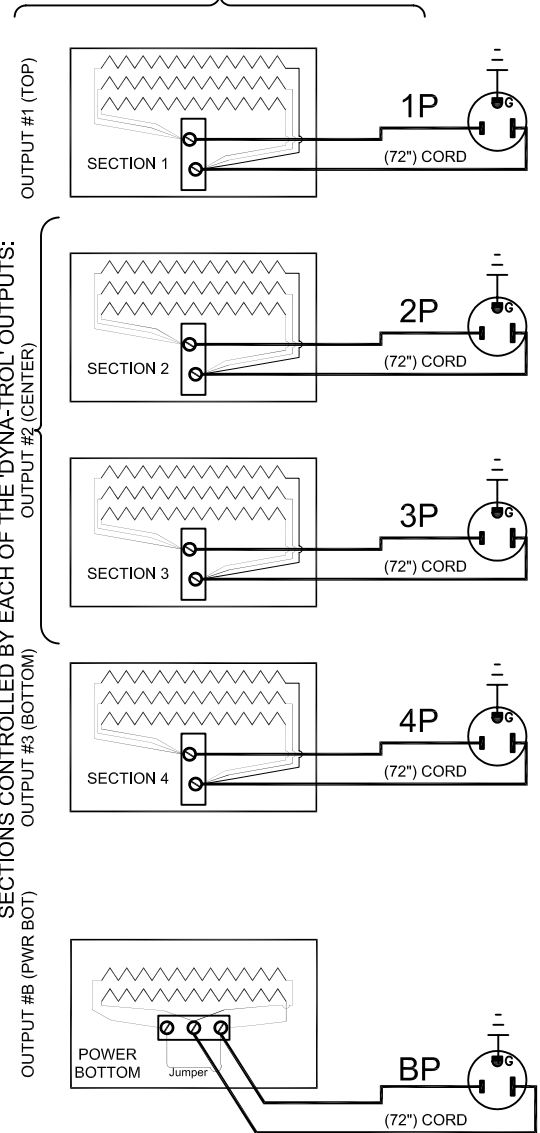

Output Numbers refer to Dyna-Trol Outputs on Automatic Kilns only.



CAUTION: DO NOT PLUG KILN SECTIONS DIRECTLY TO LINE VOLTAGE

| REV# | DATE | REVISION DESCRIPTION |
|------|---------|---|
| A | 6/29/09 | REPLACED UL MARK WITH MET CERTIFIED MARK & ADDED NEW LOGO |
| 0 | 9/25/02 | MISC CHANGES FOR RELEASE |

L Kilns
hotkilns.com
505 SHARPTOWN ROAD
SWEDESBORO, NJ 08085
PHONE: (856) 294-0077
FAX: (856) 294-0070

TITLE **DaVINCI KILN WIRING DIAGRAM**
MODELS T3436-PB & T3436-D-PB
1 or 3 PHASE KILN ASSEMBLY
4 SECTIONS, With Power Bottom

| | | |
|---------------------------------------|--------------------|-----------------------------|
| DRAWN BY G.W.L. | REV. CODE A | DRAWING NO. K140-111 |
| DATE 4/11/01 | SCALE 1 = 8 | |
| CHK G.D.L. | APP | |
| JOB NO | SER NO | SHEET NO. OF |
| FILE NAME L:\EVL\KILN\WIRDGKLN | MADE FROM | DAVINCNK105-102.dwg |