

SINGLE PHASE MODELS:

MODELS XB3245-PB & XB3245-D-PB		
VOLTAGE	208 / 1 / 50-60	
KW	40.2	
FULL LOAD AMPS	L1	L2
	193.4	193.4
POWER SUPPLY	FUSE	WIRE
	250A	350 MCM
ELEMENTS (E-X-320B/20)	QTY	OHMS
	17	18.3
VOLTAGE	220 / 1 / 50-60	
KW	40.2	
FULL LOAD AMPS	L1	L2
	182.8	182.8
POWER SUPPLY	FUSE	WIRE
	250A	350 MCM
ELEMENTS (E-X-320B/40)	QTY	OHMS
	17	20.5
VOLTAGE	240 / 1 / 50-60	
KW	40.2	
FULL LOAD AMPS	L1	L2
	167.6	167.6
POWER SUPPLY	FUSE	WIRE
	225A	250 MCM
ELEMENTS (E-X-320B/30)	QTY	OHMS
	17	24.3

THREE PHASE MODELS:

MODELS XB3245-PB & XB3245-D-PB		
VOLTAGE	208 / 3 / 50-60	
KW	40.2	
FULL LOAD AMPS	L1	L2
	108.5	118.2
POWER SUPPLY	FUSE	WIRE
	150A	2/0 AWG
ELEMENTS (E-X-320B/20)	QTY	OHMS
	17	18.3
VOLTAGE	220 / 3 / 50-60	
KW	40.2	
FULL LOAD AMPS	L1	L2
	102.6	111.8
POWER SUPPLY	FUSE	WIRE
	150A	2/0 AWG
ELEMENTS (E-X-320B/40)	QTY	OHMS
	17	20.5
VOLTAGE	240 / 3 / 50-60	
KW	40.2	
FULL LOAD AMPS	L1	L2
	94.0	102.5
POWER SUPPLY	FUSE	WIRE
	150A	2/0 AWG
ELEMENTS (E-X-320B/30)	QTY	OHMS
	17	24.3

1 PHASE CONTROL PANELS:

MODEL	(AUTO/MANUAL)	WIRING DIAGRAM
XB3245-PB	(MANUAL)	K265-107
XB3245-D-PB	(AUTO)	K265-157

3 PHASE CONTROL PANELS:

MODEL	(AUTO/MANUAL)	WIRING DIAGRAM
XB3245-PB	(MANUAL)	K265-108
XB3245-D-PB	(AUTO)	K265-158



SEE CONTROL PANEL WIRING DIAGRAM FOR WIRING CONNECTIONS TO KILN ZONE RECEPTACLES

NOTES:

Industrial & commercial applications may require the installation of a LOCKOUT/TAGOUT device to prevent the Kiln from operating during maintenance.

This Kiln is recommended to be wired & connected to an approved U. L. & NEC configured disconnect switch and properly fused according to the KW load specification listed on the Kiln Nameplate. L&L Kiln Mfg., Inc., also recommends fuses rather than circuit breakers to prevent nuisance tripping.

ELECTRICAL PARTS LIST

SYMBOL	QTY	DESCRIPTION	CUSTOMER PART NO.
P	6	72" PLUGS NEMA 6-50P	L-G-PC50/72

KILN ASSEMBLY

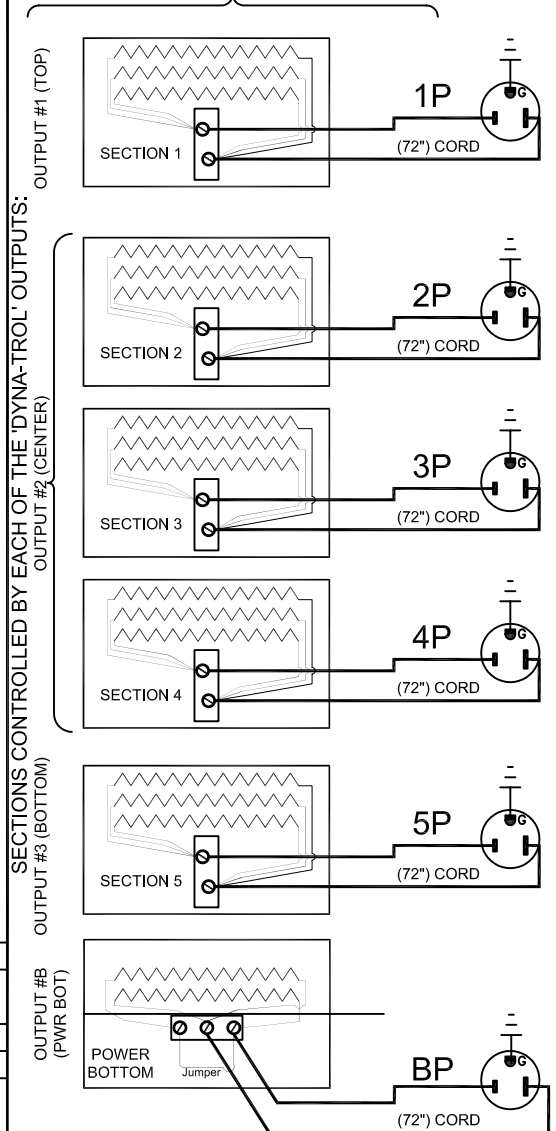

Output Numbers refer to Dyna-Trol Outputs on Automatic Kilns only.



CAUTION: DO NOT PLUG KILN SECTIONS DIRECTLY TO LINE VOLTAGE

REV#	DATE	REVISION DESCRIPTION
A	6/22/09	REPLACED UL MARK WITH MET CERTIFIED MARK & ADDED NEW LOGO
0	5/10/04	FIRST ISSUE

hotkilns.com
 505 SHARPTOWN ROAD
 SWEDESBORO, NJ 08085
 PHONE: (856) 294-0077
 FAX: (856) 294-0070

DaVINCI KILN WIRING DIAGRAM
MODELS XB3245-PB & XB3245-D-PB
1 or 3 PHASE KILN ASSEMBLY
5 SECTIONS, With Power Bottom

DRAWN BY	G.D.L.	REV. CODE	A	DRAWING NO.	K129-113
DATE	5/10/04	SCALE	1 = 8		
CHK	G.D.L.	APP			
JOB NO.		SER NO.		SHEET NO.	1 OF 1
FILE NAME	L:\EVL\KILN\WIRING\KLN	MADE FROM			
	IK129-113.dwg				IK129-111.dwg