

SINGLE PHASE MODELS:

MODELS J245-PB & JD245-PB	
VOLTAGE	208 / 1 / 50-60
KW	16.8
FULL LOAD AMPS	L1 L2 L3 80.6 80.6 X
POWER SUPPLY	FUSE WIRE 100A 1 AWG
ELEMENTS (E-J-2300/20)	QTY OHMS 11 28.4
VOLTAGE	220 / 1 / 50-60
KW	17.7
FULL LOAD AMPS	L1 L2 L3 80.6 80.6 X
POWER SUPPLY	FUSE WIRE 100A 1 AWG
ELEMENTS (E-J-2300/40)	QTY OHMS 11 30.0
VOLTAGE	240 / 1 / 50-60
KW	19.4
FULL LOAD AMPS	L1 L2 L3 80.6 80.6 X
POWER SUPPLY	FUSE WIRE 100A 1 AWG
ELEMENTS (E-J-2300/30)	QTY OHMS 11 32.7

THREE PHASE MODELS:

MODELS J245-PB & JD245-PB	
VOLTAGE	208 / 3 / 50-60
KW	16.8
FULL LOAD AMPS	L1 L2 L3 44.4 50.8 44.4
POWER SUPPLY	FUSE WIRE 70A 4 AWG
ELEMENTS (E-J-2300/20)	QTY OHMS 11 28.4
VOLTAGE	220 / 3 / 50-60
KW	17.7
FULL LOAD AMPS	L1 L2 L3 44.4 50.8 44.4
POWER SUPPLY	FUSE WIRE 70A 4 AWG
ELEMENTS (E-J-2300/40)	QTY OHMS 11 30.0
VOLTAGE	240 / 3 / 50-60
KW	19.4
FULL LOAD AMPS	L1 L2 L3 44.4 50.8 44.4
POWER SUPPLY	FUSE WIRE 70A 4 AWG
ELEMENTS (E-J-2300/30)	QTY OHMS 11 32.7

1 PHASE CONTROL PANELS:

MODEL	(AUTO/MANUAL)	WIRING DIAGRAM
J245-PB	(MANUAL)	K263-109
JD245-PB	(AUTO)	K263-159

3 PHASE CONTROL PANELS:

MODEL	(AUTO/MANUAL)	WIRING DIAGRAM
J245-PB	(MANUAL)	K263-110
JD245-PB	(AUTO)	K263-160



SEE CONTROL PANEL WIRING DIAGRAM FOR WIRING CONNECTIONS TO KILN ZONE RECEPTACLES

NOTES:

Industrial & commercial applications may require the installation of a LOCKOUT/TAGOUT device to prevent the Kiln from operating during maintenance.

This Kiln is recommended to be wired & connected to an approved U. L. & NEC configured disconnect switch and properly fused according to the KW load specification listed on the Kiln Nameplate. L&L Kiln Mfg., Inc., also recommends fuses rather than circuit breakers to prevent nuisance tripping.

ELECTRICAL PARTS LIST

SYMBOL	QTY	DESCRIPTION	CUSTOMER PART NO.
P	6	45" PLUGS NEMA 6-20P	L-J-JC45/00

KILN ASSEMBLY

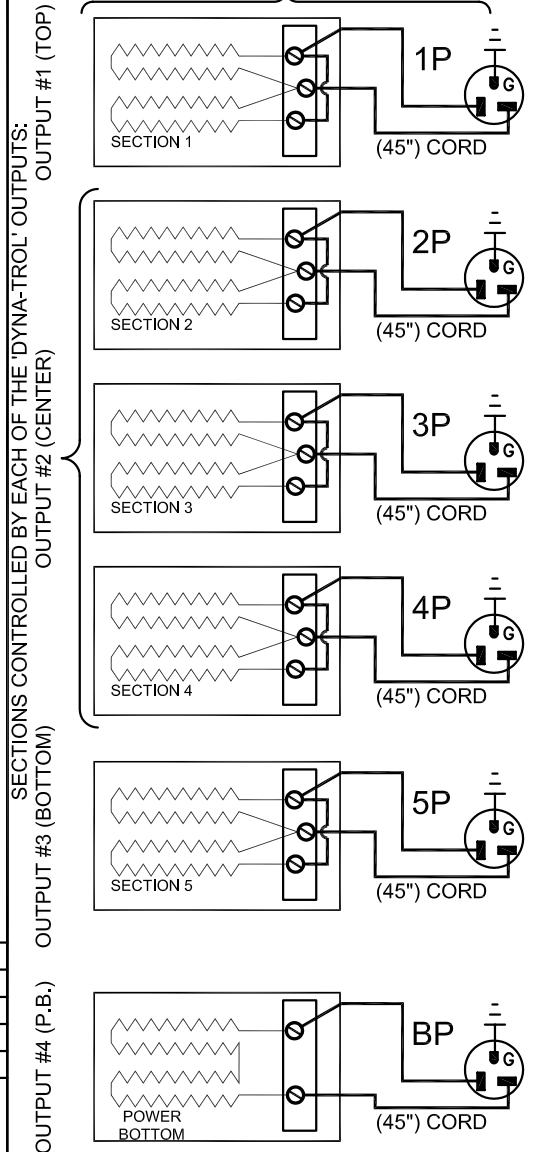

Output Numbers refer to Dyna-Trol Outputs on Automatic Kilns only.



CAUTION: DO NOT PLUG KILN SECTIONS DIRECTLY TO LINE VOLTAGE

REV#	DATE	REVISION DESCRIPTION
A	10/23/09	REPLACED UL MARK WITH MET CERTIFIED MARK & ADDED NEW LOGO
0	9/16/02	MISC CORRECTIONS FOR RELEASE
P1	11/22/00	CORRECTED MISC TABULAR INFO

L Kilns hotkilns.com
 505 SHARPTOWN ROAD
 SWEDESBORO, NJ 08085
 PHONE: (856) 294-0077
 FAX: (856) 294-0070

TITLE JUPITER KILN WIRING DIAGRAM
 MODELS J245-PB and JD245-PB
 1 or 3 PHASE KILN ASSEMBLY
 5 SECTIONS, With Power Bottom

DRAWN BY	G.D.L.	REV. CODE	A	DRAWING NO.	K039-111
DATE	10/20/99	SCALE	1 = 8	SHEET NO.	1 OF 1
CHK	G.D.L.	APP		FILE NAME	L:\EVL\KILN\WIRING\KLN\K039-111.DWG
JOB NO.		SER NO.		MADE FROM	USERIES\K039-110.dwg