

XB3218

Temperature Rating: Cone 10

Volume: 9.7 Cubic Feet

Brick Thickness: 3" Brick

Inside: 30.5" D x 18" H

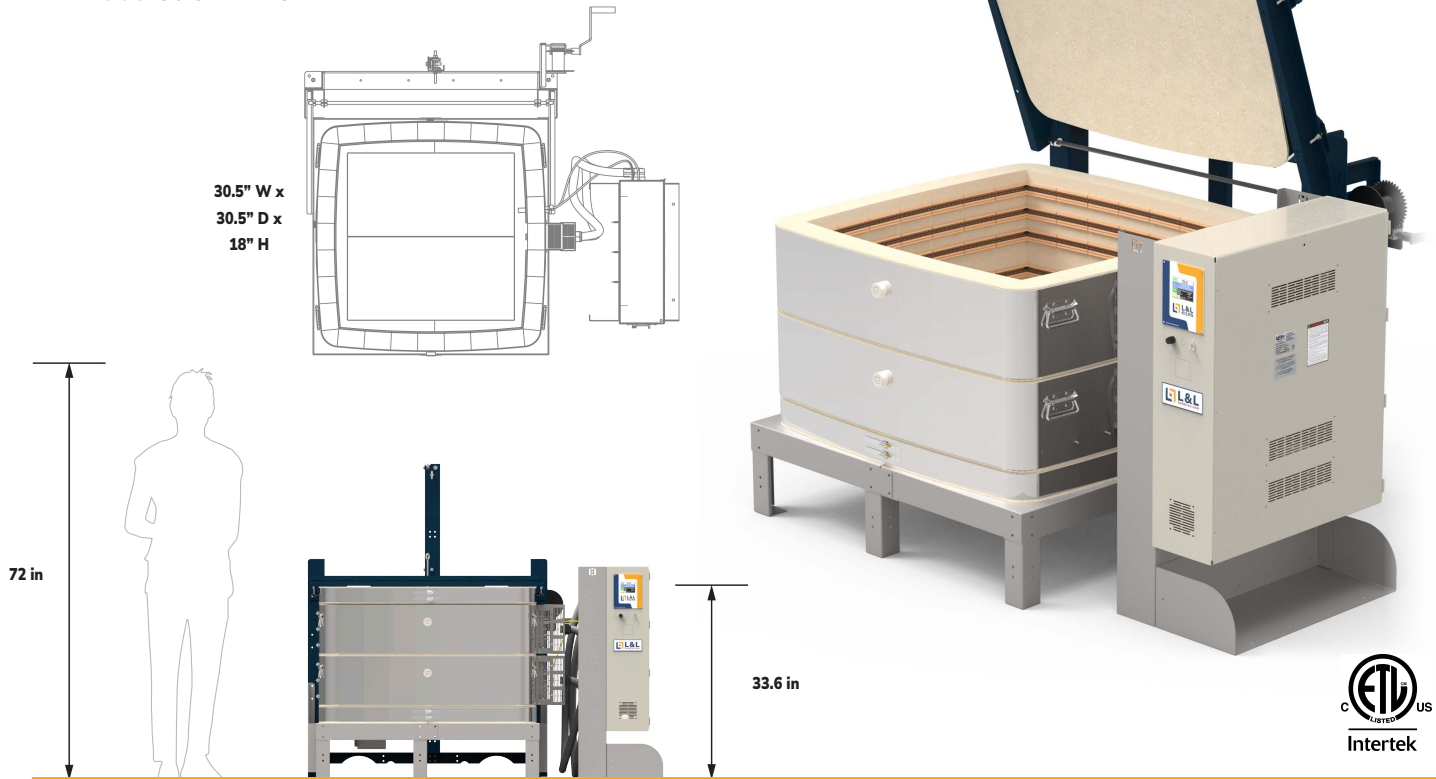

Large volume square kilns with adjustable height. DaVinci kilns are great for production and tiles. Includes arched sides for strength and counterbalanced lid.

- **Genesis Touch Screen Control** with Dynamic Zone Control
- **Cone 10 • 2350°F • 1290°C**
- **Lid Winch System** easy and safe single person lift
- **Safety Latches for Lid**
- **Welded angle-iron powder-coated stand and hinge**
- **3" brick**
- **Type K Thermocouples (2)**
 - with protection tubes
- **Strong arched sides** with extra space added to interior dimensions for good air circulation
- **Three elements per 9" section**
- **Ceramic Element Terminals**
- **Hard Ceramic Element Channels**
- **Plug in kiln sections** (except 480 volt models)
- **Floor mounted control panel**
- **Solid State Power Controls**
- **c-ETL-us listed to UL499 Standards**
- **See hotkilns.com/xb3218 for all features and options**

GENERAL DIMENSIONS

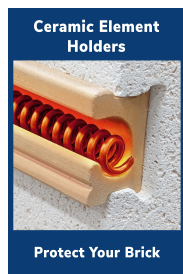

TRUST YOUR KILN
hotkilns.com

Manufactured in Swedesboro, NJ
800-750-8350 • sales@hotkilns.com

Bulletin No: BL-XB3218 REV: A



USA

Standard Models							Powered Bottom Models				
Model Number	Part Number	Volt/Phase	Watts	Amps	Wire Size	Fuse Size	Part Number	Watts	Amps	Wire Size	Fuse Size
XB3218-D-240	K-X-3218/31	240/1P	14,196	59.2	3 ga	80	K-X-321P/31	18,928	78.9	1 ga	100
XB3218-D-240-3P	K-X-3218/32	240/3P	14,196	51.2	4 ga	70	K-X-321P/32	18,928	51.2	4 ga	70
XB3218-D-208	K-X-3218/21	208/1P	14,196	68.3	2 ga	90	K-X-321P/21	18,928	91.0	1/0	125
XB3218-D-208-3P	K-X-3218/22	208/3P	14,196	59.1	3 ga	80	K-X-321P/22	18,928	59.1	3 ga	80
XB3218-D-480-3P	K-X-3218/62	480/3P	14,196	17.1	12 ga	25	K-X-321P/62	18,928	25.6	8 ga	40

WORLD

XB3218-D-220	K-X-3218/41	220/1P	14,196	64.5	2 ga	90	K-X-321P/41	18,928	86.0	1 ga	110
XB3218-D-380-3PY	K-X-3218/52	380/3PY	14,196	32.3	6 ga	50	K-X-321P/52	18,928	32.3	6 ga	50
XB3218-D-400-3PY	K-X-3218/82	400/3PY	14,196	30.9	8 ga	40	K-X-321P/82	18,928	30.9	8 ga	40
XB3218-D-415-3P4	K-X-3218/72	415/3PY	14,196	29.6	8 ga	40	K-X-321P/72	18,928	29.6	8 ga	40



Control: Full digital touchscreen Genesis control with easy-to-use interface, WiFi enabled app, and simple programs for firing ceramics or glass.

For Model Number of Powered Bottom Model: Add a "PB" after the "D" (Example = X3227-D-PB-240-1).

UL Listing: c-ETL-us listed.

Control Panels: Floor standing panel. NEMA 1 panel are recommended but not required for 480 volts.

480 Volt Models with Quad Element Option: See website kiln pages for electrical specifications.

Crating: Comes fully crated. Easily disassembles for installation.



FURNITURE KIT FOR XB3218

Part Number: H-X-K218/00

Includes: Four 28" X 14" rectangular shelves (3/4" thick), six each 1/2", 1", 2", 4", 6", and 8" square posts, and one pair heat resistant gloves.