

- WALL/KILN SPACING:** 12" [30.5cm] SPACING BETWEEN SIDES OF KILN AND WALLS OR OTHER OBJECTS. 18" [45.7cm] IS RECOMMENDED. LEAVE AT LEAST 18" [45.7cm] BETWEEN TWO KILNS. LEAVE AT LEAST 22" [55.9cm] FROM THE BACK OF THE KILN TO THE WALL TO GIVE ENOUGH SPACE FOR THE WINCH CRANK.
- AMBIENT VENTILATION:** SEE CHART TO RIGHT FOR RATINGS. TO CALCULATE REQUIREMENTS, SEE [hotkilns.com/calculate-kiln-room-ventilation](http://hotkilns.com/calculate-kiln-room-ventilation).
- KILN VENTILATION:** L&L VENT-SURE KILN VENT RECOMMENDED FOR SAFETY AND LONGER ELEMENT LIFE. OPTIONAL CONTROL ALLOWS VENT TO BE TURNED ON AND OFF WITH CONTROL.

- OTHER INFO:** REFER TO INSTALLATION INSTRUCTIONS AND CAUTIONS INSTRUCTIONS FOR OTHER REQUIREMENTS AND SAFETY INFORMATION. REFER TO WIRING DIAGRAM FOR ELECTRICAL HOOKUP INFORMATION.
- MAX LOAD WEIGHT:** SEE [hotkilns.com/load-weight](http://hotkilns.com/load-weight).
- WEIGHT OF KILN:** 735 LBS, 333 KG

BTUS/ KILOJOULES PER HOUR NEEDED TO BE VENTED WITH AMBIENT ROOM VENTILATION (THIS IS IN ADDITION TO KILN VENTING):

AT TEMP F	BTUS	AT TEMP C	KILOJOULES
1800F	17015	980C	17951
2000F	19892	1095C	20988
2232F	23490	1222C	24783
2350F	25425	1285C	26825

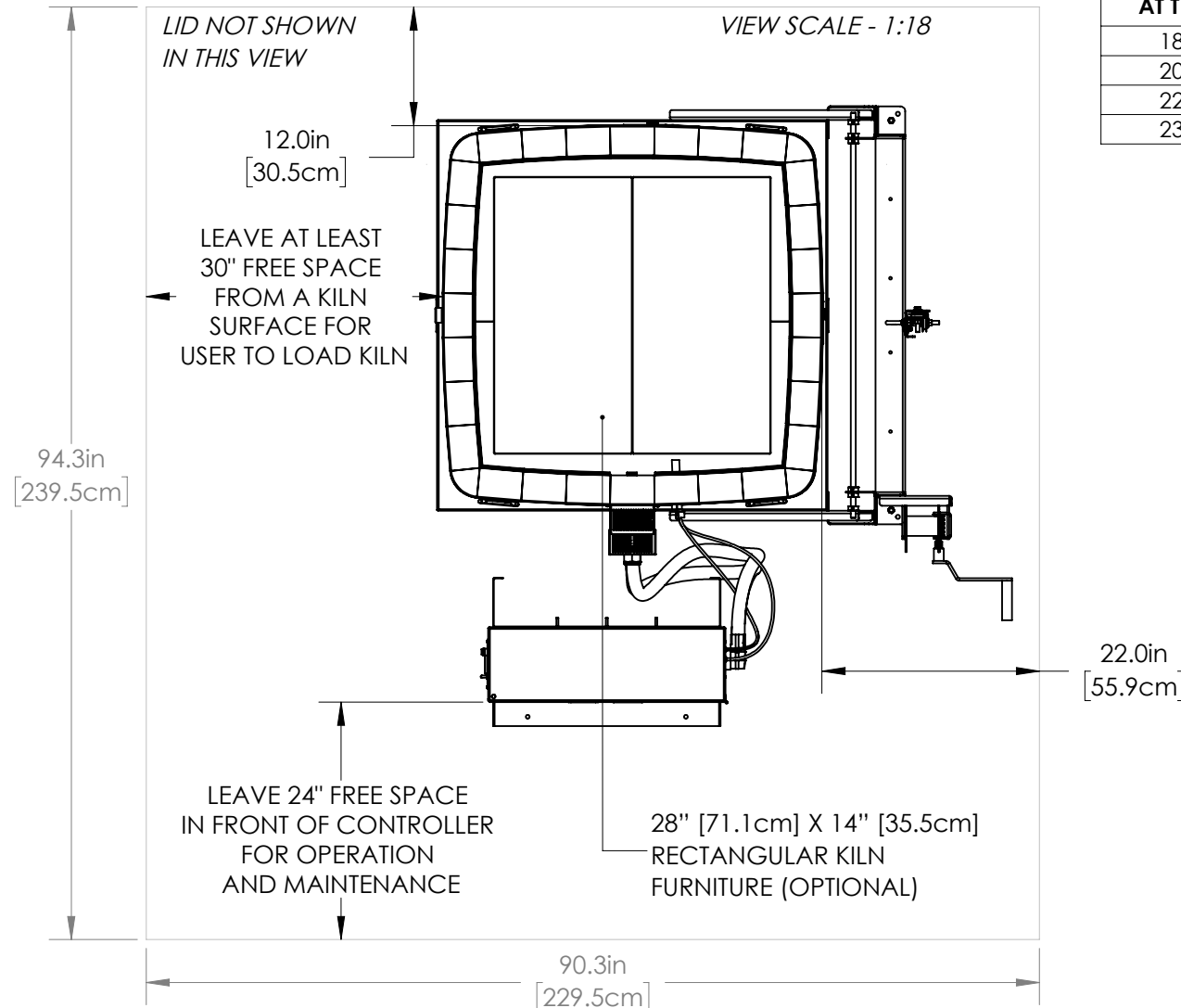

THIS MODEL IS DIRECT WIRED. THERE IS NO POWER CORD.

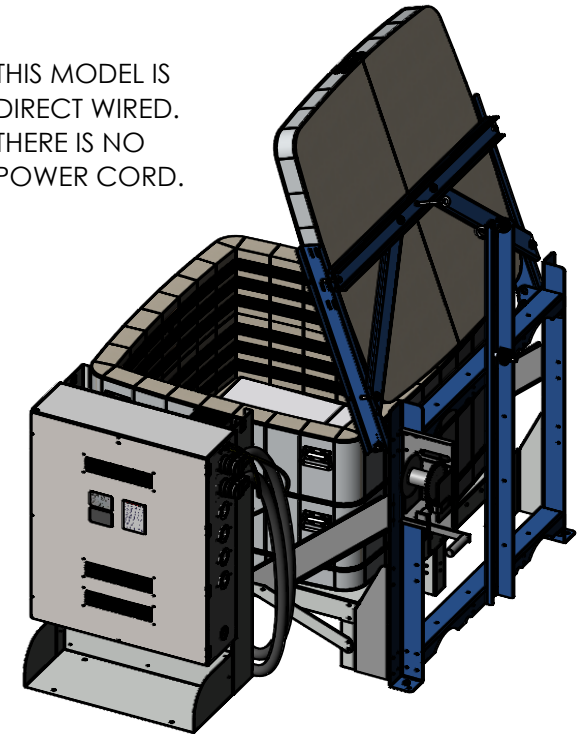

LID NOT SHOWN  
IN THIS VIEW

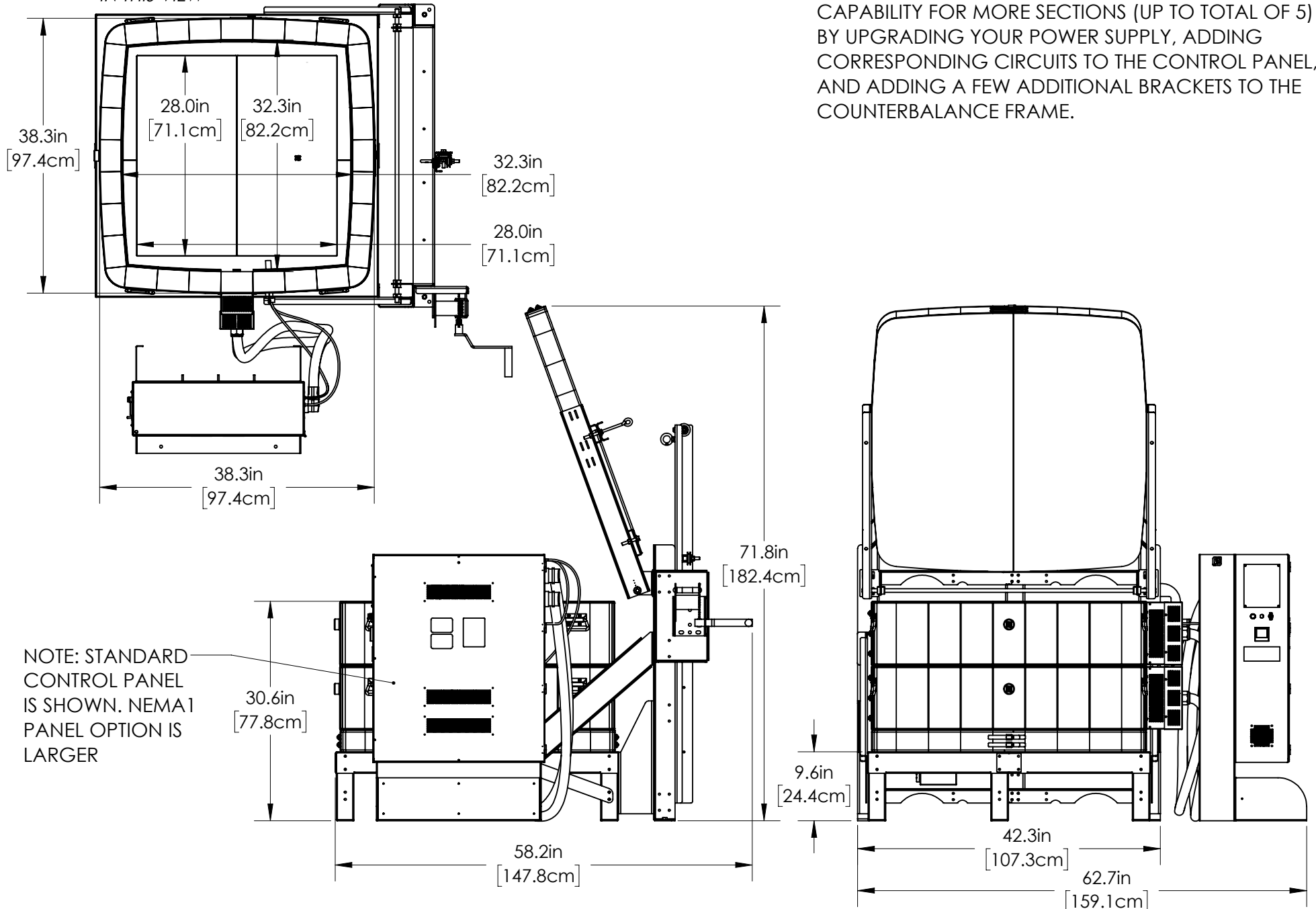

EXPANDABILITY: THIS MODEL HAS FUTURE EXPANSION CAPABILITY FOR MORE SECTIONS (UP TO TOTAL OF 5) BY UPGRADING YOUR POWER SUPPLY, ADDING CORRESPONDING CIRCUITS TO THE CONTROL PANEL, AND ADDING A FEW ADDITIONAL BRACKETS TO THE COUNTERBALANCE FRAME.

MADE FROM NEW	DRAWN BY LL	DATE 06/09/2026	SCALE 1:18	TITLE X3218-D (3" BRICK) DAVINCI GENERAL DIMENSIONS		505 SHARPTOWN RD SWEDESBORO NJ 08085 PH: (856) 294-0077 FAX: (856) 294-0070	REV A	SHEET OF 2/3	DRAWING NO. 300-000-40-2
------------------	----------------	--------------------	---------------	--	---	--	----------	-----------------	-----------------------------

5

4

3

2

1

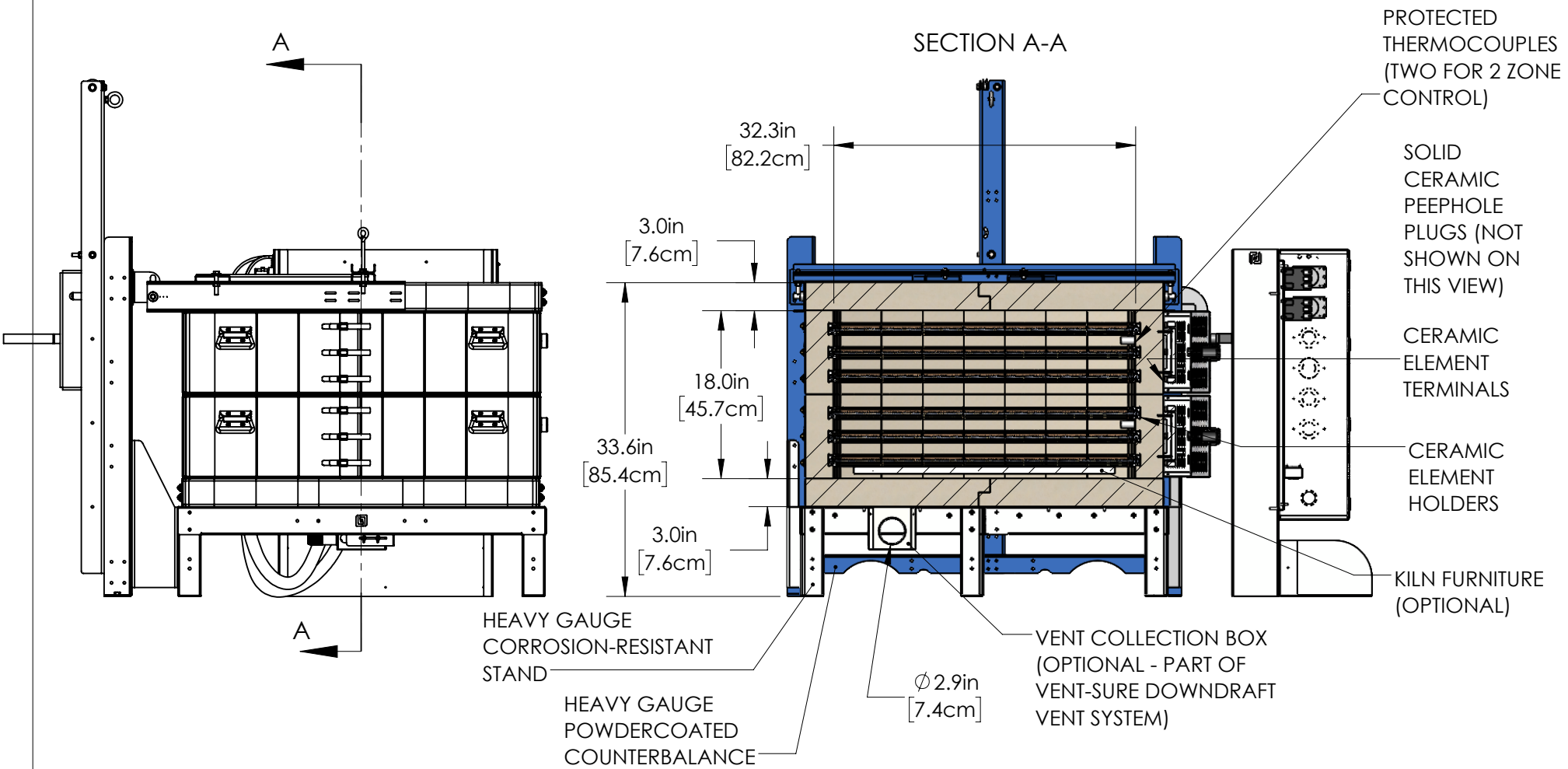

OPTIONAL FURNITURE KIT: (4) 28" [71.1cm] X 14" [35.5cm] RECTANGULAR SHELVES, (6) EACH 1/2", 1", 2", 4", 6" & 8" SQUARE POSTS

MADE FROM NEW	DRAWN BY LL	DATE 06/09/2026	SCALE 1:16	TITLE X3218-D (3" BRICK) DAVINCI GENERAL DIMENSIONS	<b>LKilns</b> hotkilns.com	505 SHARPTOWN RD SWEDESBORO NJ 08085 PH: (856) 294-0077 FAX: (856) 294-0070	REV <b>A</b>	SHEET OF 3/3	DRAWING NO. 300-000-40-2
------------------	----------------	--------------------	---------------	--	-------------------------------	--	-----------------	-----------------	-----------------------------

5

4

3

2

1