

1. **WALL/KILN SPACING:** 12" [30.5cm] SPACING BETWEEN SIDES OF KILN AND WALLS OR OTHER OBJECTS. 18" [45.7cm] IS RECOMMENDED. LEAVE AT LEAST 18" [45.7cm] BETWEEN TWO KILNS.
2. **OTHER INFO:** REFER TO INSTALLATION INSTRUCTIONS AND CAUTIONS INSTRUCTIONS FOR OTHER REQUIREMENTS AND SAFETY INFORMATION. REFER TO WIRING DIAGRAM FOR ELECTRICAL HOOKUP INFORMATION.
3. **WEIGHT OF KILN:** 77 LBS, 35 KG
WEIGHT OF BODY AND LID: 68 LBS, 31 KG
4. **PACKAGING:** SHIPS IN 2 BOXES

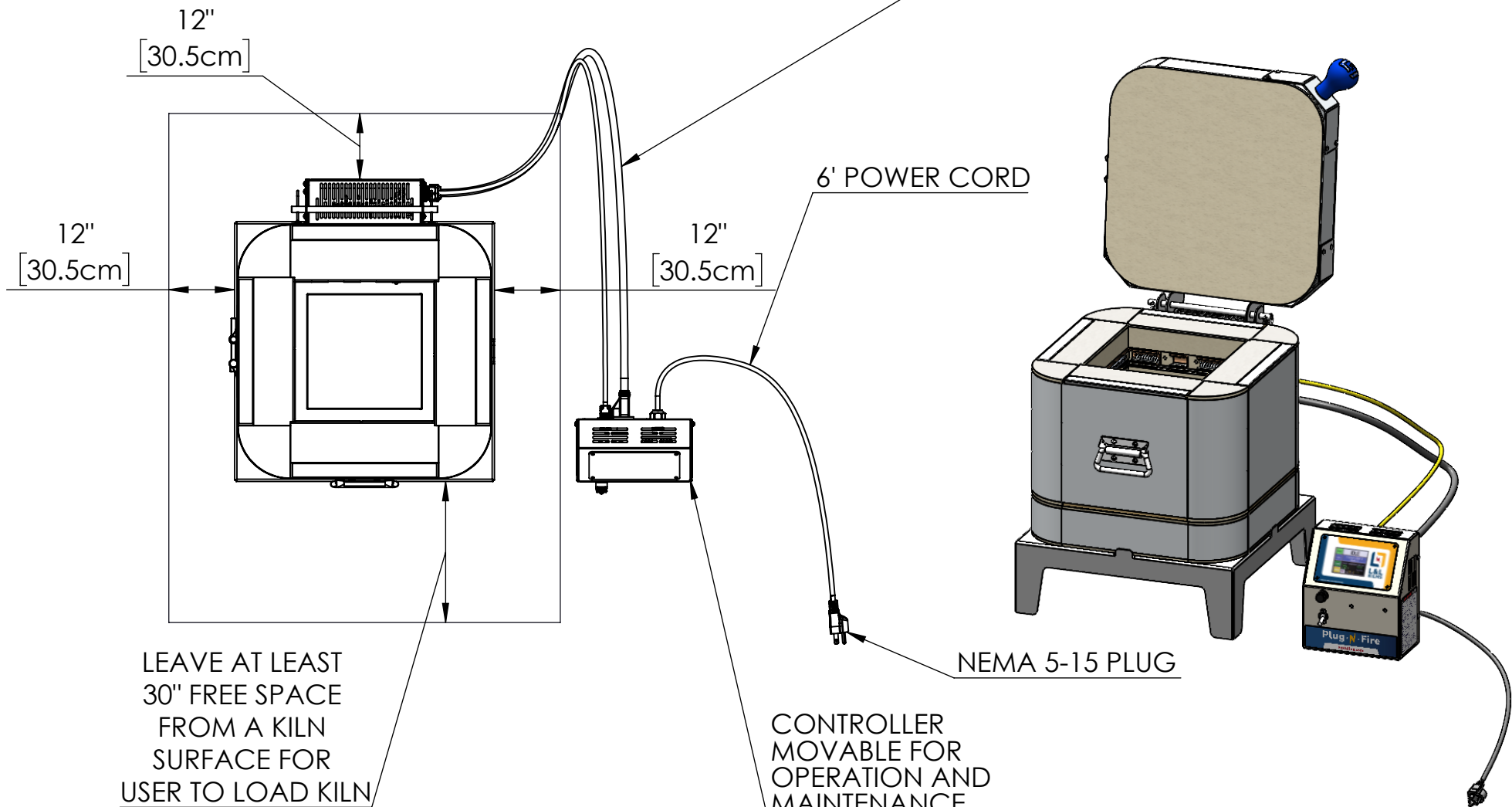

3' CORDS FOR
ELEMENT POWER
AND
THERMOCOUPLE

6' POWER CORD

NEMA 5-15 PLUG

CONTROLLER
MOVABLE FOR
OPERATION AND
MAINTENANCE

4

3

2

1

D

D

C

C

B

B

A

A

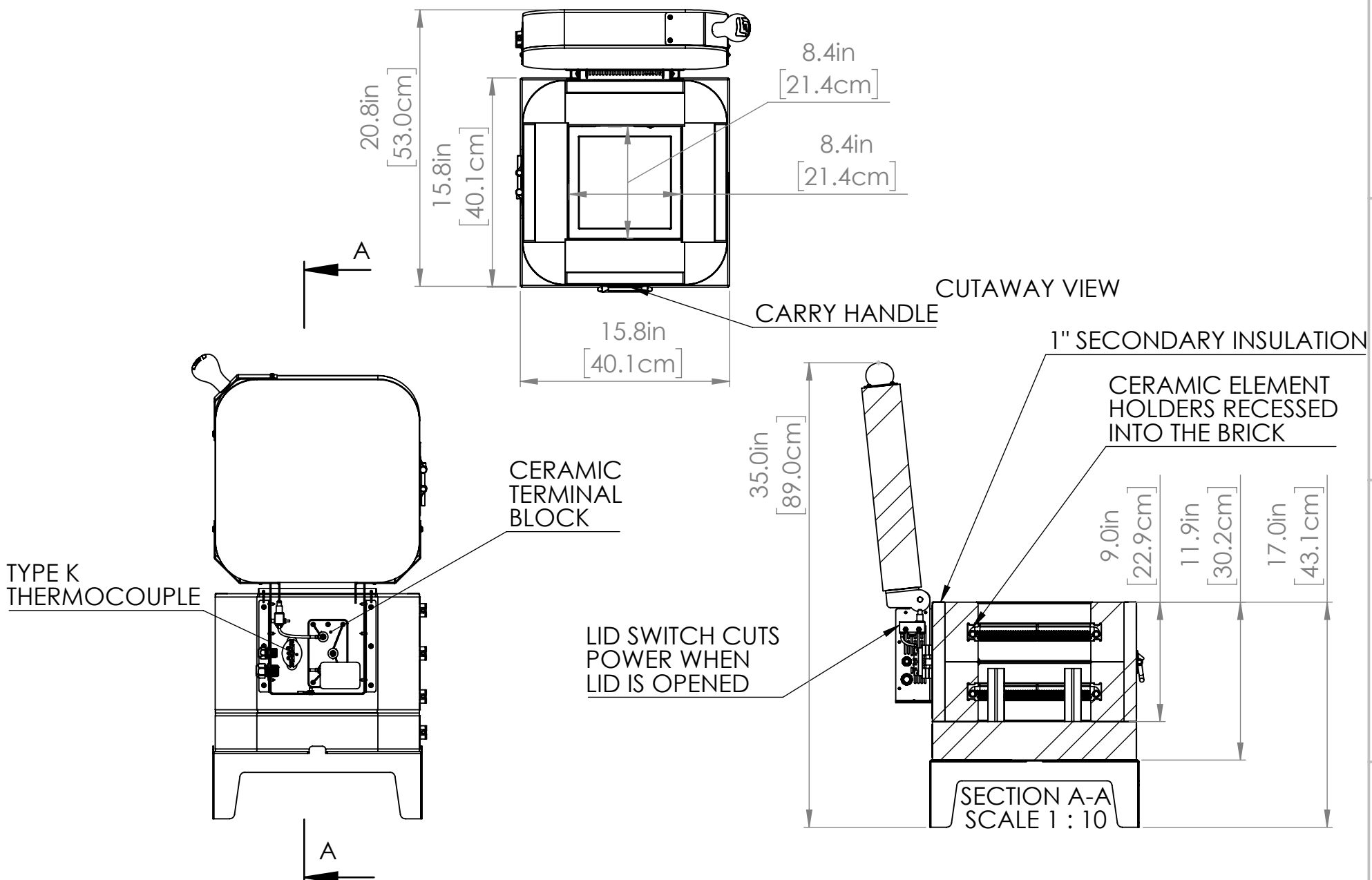

INCLUDED FURNITURE KIT: (1) 7" X 7" [17.8cm X 17.8cm] SQUARE SHELF, (3) 3" TRIANGULAR POSTS

MATERIAL:

DRAWN BY
NJO

DATE
3/27/2024

SCALE
1:20

TITLE
Plug-N-Fire Hobby Kiln



505 SHARPTOWN RD
SWEDESBORO NJ 08085
PH: (856) 294-0077
FAX: (856) 294-0070

REV
0.2

SHEET OF
2/2

DRAWING NO.
400-000-00

4

3

2

1