

Jupiter

Top-Loading Sectional Kilns

Highly customizable Jupiter kilns have a long pedigree back to the mid 1970s and have been continuously updated since then. They feature plug in kiln sections and completely separate control panels - unique in the kiln industry.

- **Plug-in Sectional Construction** makes Jupiter kilns very flexible. They can be easily taken apart
- **Hard Ceramic Element Holders** protect brick and make element changes fast and easy
- **Dynamic Zone Control** keeps temperatures uniform throughout kiln
- **Remote Panel** protects electronics and makes servicing easy
- **Protected Thermocouples**
- **Spring-Assist Hinge** on larger models does not need side support bars - makes loading easy from all sides
- **Super-Strong Aluminized Steel Stand** securely supports vent system
- **Customize to meet your exact needs. Every kiln is built to order**



505 Sharptown Road • Swedesboro, NJ 08085
Phone: 856.294.0077 • Fax: 856.294.0070
sales@hotkilns.com • hotkilns.com

KILNS BUILT TO LAST

Bulletin No: JD-0121



Jupiter Top Loading Sectional Kilns

Unique L&L Features with Lasting Benefits

CONE 10 RATING (FOR MOST MODELS)

Cone 10, 2350°F, 1290°C (see specification pages)

CHOICE OF INSULATION

Choice of 2.5" or 3" K23 firebrick. (3" only on JD2900 Series). (3" brick recommended for high fire applications (over cone 1 - 2000F). See hotkilns.com/brick-study)

PATENTED CERAMIC ELEMENT HOLDERS

Protect brick from loading damage, keep elements from falling out of grooves, makes changing elements easy, and optimises heat transfer to load. Kiln lasts longer! (hotkilns.com/ceramic-holders)



BRICK COATING FOR DURABILITY

Proprietary reflective brick coating. This helps firebrick stay strong on the surface, helps prevent dusting on your work, and keeps the kiln clean inside. (hotkilns.com/reflective-coating)

HEAVY-DUTY LARGE ELEMENTS

Heavy-duty. 2 elements per section on JD1800 and JD2300 Series. Three elements per section on JD2900 Series. *Quad elements, which increase the element wire by having four rows of elements per section, are optional on all models. See Page 6.*

EXTRA CASE CLAMPS

Stainless worm gear case clamps keep case together and allow for adjustment over time. Three per 9" section, Two on the top and bottom. (hotkilns.com/case-clamps)

"EASY-OPEN, EASY-LOAD" SPRING-LOADED LID OPENS WIDE FOR LOADING

On JD2300 and JD2900 models, the whole kiln supports the lid (not just one section). Our positive safety pin secures the lid safely. No side support bars get in the way of loading when the lid is fully tilted back. (hotkilns.com/spring-hinge)



Note the backward angle with no side support bars for easy unobstructed loading.

STAINLESS HINGE ON JD1800 MODELS

Chains secure the lid in place when open. (hotkilns.com/simple-hinge)



LID BRICK IS SECURED WITH CLIPS

Stainless Steel clips secure lids - not friction.
(hotkilns.com/lid-clips)

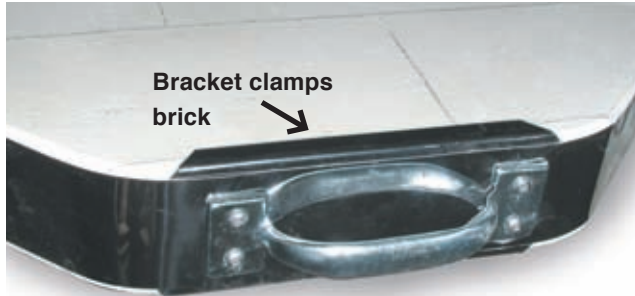

SOLID PEEPHOLE PLUGS



Solid (non-fragile) ceramic plug with heat-locked mushroom head. 1" diameter full-view non-tapered.
(hotkilns.com/peephole-plugs)

HEAVY-DUTY FULL-SUPPORT STAND

Heavy-duty 14 gauge solid stand with multiple bends for strength. Bolt on legs. Feet protectors included. Optional Vent Bypass Collection Box bolts onto underneath of stand with included studs. *Rolling stand is optional. See page 6.*
(hotkilns.com/full-stand)

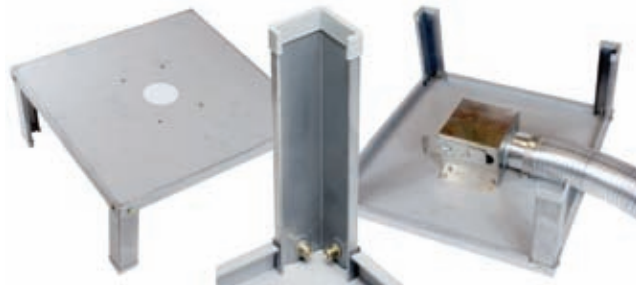

THE ULTIMATE SECTIONAL KILN

Sectional kiln construction makes Jupiter kilns easy to move, set up and disassemble for maintenance or for loading. Sections are completely separate from the control panel. Each section has its own plug that plugs into a special receptacle in the control panel. Bottom is reversible. See page 11.
(hotkilns.com/sectional-jupiter)

CORROSION RESISTANT CONSTRUCTION

Stainless steel wrapped around brick. All stainless screws on case. Stand is galvanized. Vent parts are stainless steel or aluminum. Hinge is stainless steel. Control box is powder coated steel. (hotkilns.com/case)

EASY MULTI-PROGRAM DYNATROL



The time-tested DynaTrol with 4 Easy-Fire programs, 6 Vary-Fire programs, PreHeat, Delay, Program & Segment Review, and Diagnostics. Control is mounted on an angled panel for easy viewing.

Optional Genesis control (see page 8) features touch screen and free Wifi App for monitoring kiln. (hotkilns.com/dynatrol)

DYNAMIC ZONE CONTROL

This is a *standard* feature with either a DynaTrol or touch-screen Genesis control. The control separately measures temperatures in the bottom, middle, and top of the kiln and automatically adjusts the heat of two or three zones during the firing. Kiln temperatures are automatically equalized to within 1/2 cone or better. Zone control automatically compensates for many loading issues and element resistance changes. Additionally, L&L kilns are fundamentally uniform because the element holders radiate the heat more evenly. (hotkilns.com/zone-control)

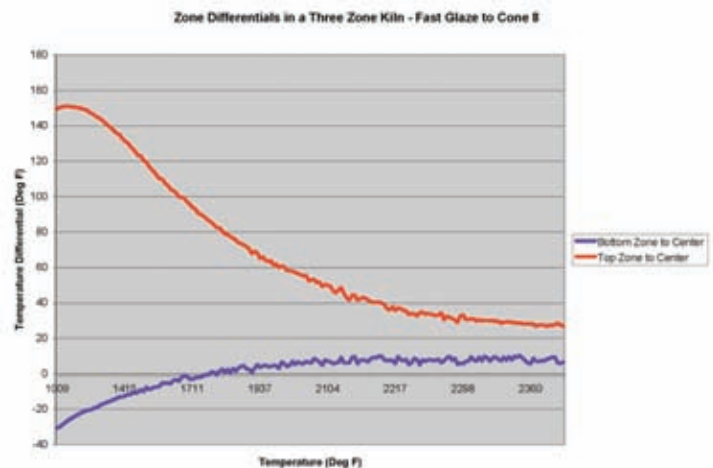

SEPARATE COOL-FIRING CONTROL PANEL

All controls and components are mounted in a separate control panel that is mounted to either the element connection box or is floor mounted. Cords from the kiln sections plug into the panel. There is an air space between the panel and the kiln which keeps the controls cool - which is critical for long term health of the electronics.



HEAVY-GAUGE TYPE K THERMOCOUPLES

Type K 8 gauge thermocouple is protected by a open ceramic protection tube. This allows the thermocouple to accurately read the kiln temperature but protects the delicate tip of the thermocouple from damage while loading. Also any metallic flakes from the thermocouple will tend to drop inside the tube where they can be vacuumed out during normal maintenance. (hotkilns.com/protected-thermocouples)



CERAMIC ELEMENT CONNECTIONS

Proprietary all-ceramic element connection block makes changing elements easy. Terminal hardware allows you to get good contact with the element with minimal effort.

(hotkilns.com/ceramic-terminal)



MERCURY FREE RELAYS

Mercury free relays are standard. *See Page 9 for optional electronic SSRs for extra long element life and quiet operation.*

TWO CHEST HANDLES KILN SECTIONS

Chest Handles make the sections easy to lift.



POWER CORD & PLUG ON MODELS UNDER 48 AMPS



50 Amp NEMA 6-50 six foot cord included for one phase.



50 Amp NEMA 15-50 six foot cord included for three phase. (All Non USA kilns are direct wired).

See *Electrical Specifications pages*. Same price for all voltages and phases.

COMPLETE VISUAL INSTRUCTIONS

No one has a better or more complete instruction manual. Our visual instructions address the needs of the artist, the installer, and the repair person. You get a fully illustrated operation and service manual. Many instructional videos are available. (hotkilns.com/videos)

L&L KILNS ARE EASY TO TROUBLESHOOT

Open up any L&L kiln control panel and see how easy it is to check amps, element resistance, and voltage. No other kiln can be serviced as quickly, easily, or inexpensively as an L&L kiln.

THREE-YEAR WARRANTY

See hotkilns.com/warranty. Email, web and phone support.

IN-DEPTH SUPPORT

One customer said: "I am truly impressed with your website, it is more than informative and your products are well designed. The fact that all the information, including repair manuals, are listed, speaks well of your dedication to customer service." Our website has thousands of pages of technical help - all easily searchable - plus we provide expert support with phone and email.

SUSTAINABLE MANUFACTURING

We use solar energy as our primary energy source.

SUPERIOR PACKAGING

Kilns are securely packed with tubes of foam molded to the kiln. Kilns are shipped in skidded cartons.

MET UL499 LISTING



c-MET-us listed to UL499 standards assures highest safety standards. (hotkilns.com/met)



Optional Kiln Furniture, Element Options, Rolling Stands, & Powered Bottoms

CONE 11 FURNITURE KITS

Shelves are high alumina cone 11 shelves. Each post kit includes six each 1/2", 1", 2", 4", 6" and 8" high square (1.5" x 1.5") cordierite posts. All furniture kits include one pair heat-resistant gloves. (hotkilns.com/kiln-furniture)



QUAD ELEMENT DESIGN

The combination of 1/2" diameter element coils, the doubled surface area of the Quad element design, and superior heat transfer of L&L's patented ceramic element holders, make this the best element system in the world today. (hotkilns.com/quad-option)



APM ELEMENTS

Special sintered alloy provides the ultimate in element life. The special sintered alloy inhibits grain growth and resistance change in the elements. (hotkilns.com/apm)

OPTIONAL CORDS

Single Phase JD18 and JD18-3 models can have a 12 foot 30 amp cord in various types. All other single phase models that are not direct wired can get a 12 foot NEMA 6-50 cord. (hotkilns.com/cord-options)

POWERED BOTTOMS

Available on J2300 and JD2900 Series. (hotkilns.com/jupiter-pb)



ROLLING STAND WITH LOCKING CASTERS

Allows kiln to be moved out of the way while not firing. L&L's rolling kiln stand features heavy gauge (14 ga) galvanized steel construction with multiple bends for extra strength, steel swivel locking casters, integrated vent collection box support, and guide rails for the kiln. Not recommended for 45" high kilns. (hotkilns.com/rolling-stands)



Ventilation Options & Accessories

DOWNDRAFT VENT SYSTEM

Vent-Sure downdraft vent vents fumes from kiln out of room and away from kiln. (hotkilns.com/vent)

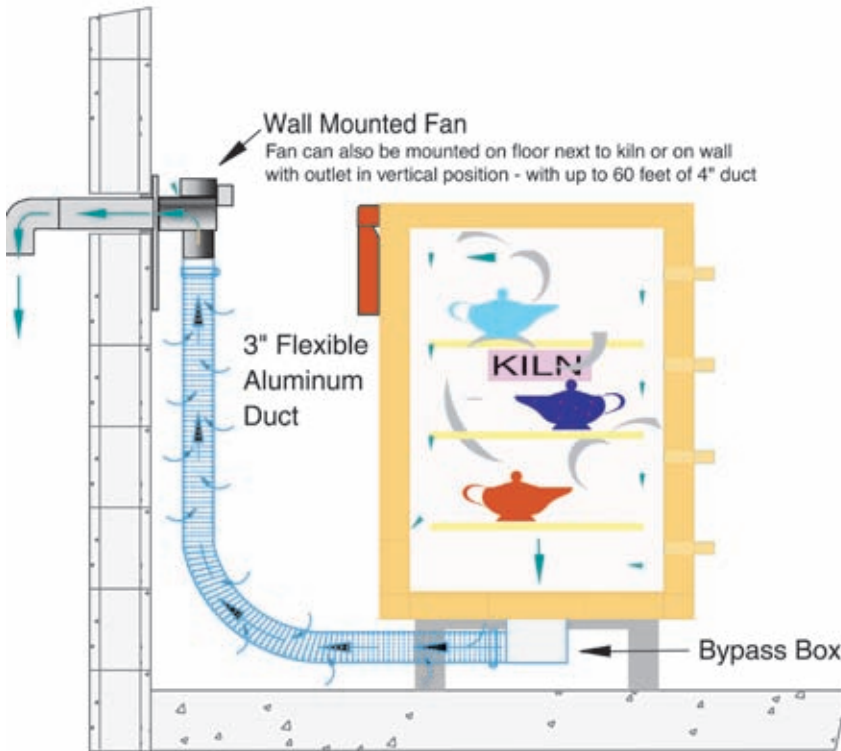

VENT-SURE FEATURES

- Downdraft venting pulls air down to bottom of kiln
- Improves temperature uniformity inside the kiln
- Powerful 130 CFM fan motor, typically mounted on wall, allows fumes to be under vacuum in your studio
- The strong fan motor helps overcome static pressure in long exhaust lines. The duct may be up to 60 feet in length, and include up to four 90° bends
- 120 volts with on/off switch on cord (240 volts available)
- 15 foot long flexible aluminum duct
- Bypass collection box mounted on kiln allows adjustment of venting.
- Fan motor, mounted away from the kiln, stays cool and no vibration is transmitted to the kiln
- The included Multi-Mounting Bracket allows you to mount the vent on the floor or, alternately, to mount the vent on a wall so that the output of the vent is pointing up.
- Three-year Limited Warranty
- c-MET-us Listed to UL499 standards for use on c-MET-us L&L Kilns



VENT CONTROL

Allows vent to be controlled with an event switch in the DynaTrol or Genesis. (For use with one kiln.) (hotkilns.com/vent-control)



VENT DOUBLER

This accessory allows you to connect two kilns to a Vent-Sure vent system. It can be added to an existing vent system or can be ordered with a new vent. In some cases you may be able to fire two kilns at once. The Vent-Sure has enough force to vent at least 25 cubic feet of kiln. That means, for instance, that two JD2927-3 kilns could be vented while firing at the same time. (hotkilns.com/doubler)

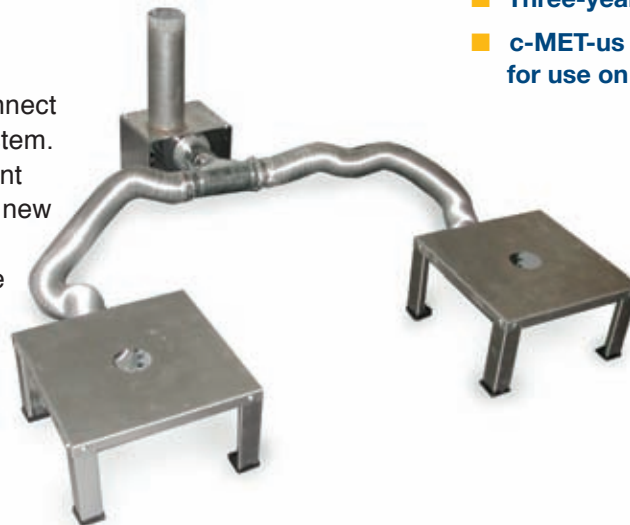

Genesis Touch Screen Control with App

GENESIS TOUCH SCREEN CONTROL

The Genesis control includes a touch screen interface and WIFI connectivity added to the proven software of the DynaTrol. More programming options and memory. Free App available to monitor kiln via WiFi. (hotkilns.com/genesis)



GENESIS FEATURES

- Touch-screen intuitive technology for easy user interface.
- Easy-to-follow screen descriptions.
- Different user-interface levels, which can be set to match the user's firing knowledge.
- Graphical display of the firing process right at the controller. This means you can graph the firing in real time and compare the program with actual results.
- Glass programs included.
- Store up to 30 custom user programs.
- Up to 32 segments per program.
- Ability to make adjustments during a firing such as add segments, add temperature, and skip segments.
- Built in diagnostics testing
- Alarm
- Error Codes
- WiFi enabled for easy software updating.
- Included Phone App allows you to monitor kiln operation remotely (with no subscription fee).



The Genesis control fits right into the control box to replace the DynaTrol. That means you can upgrade anytime!



See a graph of your firing before you fire, while you fire and after you fire.

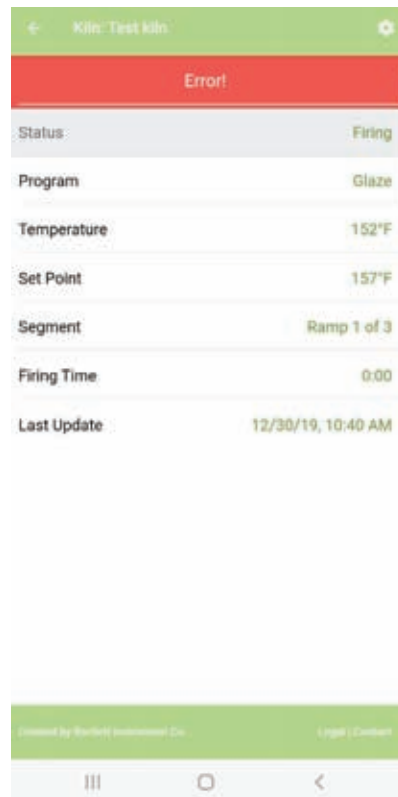

This shows the view you get on your phone with the Kiln Aid Phone app. Simply download the Kiln Aid phone app from your Google Play Store or Apple App Store, add your kiln, and begin monitoring as your kiln progresses through a firing. See temperatures, where you are in a program cycle, what program you are firing and error notifications.

More Control & Power Options

TYPE S THERMOCOUPLES

The best thermocouple for constant high fire applications. No thermocouple drift. Priced per thermocouple. Note that kilns with four or more sections still only have a three zone control.

(hotkilns.com/type-s)

PYROCIL SHEATHED THERMOCOUPLES

For greater sensitivity to temperature change. Use below 2200°F for sensitivity (glass is a good example). Priced per thermocouple. These are useful for sensitive industrial applications.

(hotkilns.com/pyrocil-tc)

KISS SOFTWARE

Kiss (kiln interface software system) connects up to 50 DynaTrol controllers to a personal computer running Windows. Monitor and control kiln remotely. For the DynaTrol only. (hotkilns.com/kiss)

SOLID STATE RELAYS

Industrial Grade Solid State Relays are quiet and result in longer element life because the switching



time is so fast the elements don't expand and contract as much. The whole system includes extra large heat sinks, special fast acting fuses, cooling fan and extra safety relays. (hotkilns.com/ssr)

Kiln shown with the special control panel that houses the SSRs and/or High Limit Control

HIGH LIMIT BACK UP CONTROL

Bartlett High Limit Control with latching relay acts as a back up to the main control. If the main control fails for any reason then this acts as a "back stop" and shuts the kiln down.

(hotkilns.com/high-limit)

BACK UP CONTACTORS

Actuated by the High Limit Back Up Digital Control, back up contactors are completely redundant power contactors so that if one or more contactors fail in a closed position, then the kiln still cannot climb above the High Limit set point. (hotkilns.com/high-limit)

120 VOLT POWER SUPPLY

If there are problems with short power outages, voltage spikes, voltage drops, or excessive environmental line noise, this can cause unpredictable behavior in the electronic control. With this option the control is powered by a separate 120 volt line (with a standard 6 foot long cord) and that voltage is filtered through an EMI (Electrical Magnetic Interference) noise filter. (hotkilns.com/noise)

NEMA1 CONTROL PANEL

These are typically used for 480 volt models. They include integrated panel stand legs.

480 VOLT OPTION

Available on J2900 Series kilns only.



Pull-Apart Option

“PULL-APART” OPTION FOR SCULPTURE

Includes floor mount stand for control panel, lift off lid with extra handles but no hinge. This option allows the entire kiln to be dismantled to make it easy to load large sculptural pieces. The kiln sections are unplugged and then taken off one at a time. You can order a hinge as well but the hinge makes the kiln harder to take apart.



The Ultimate Sectional Kiln

WHAT IS GOOD ABOUT SECTIONAL CONSTRUCTION?

Sectional kiln construction make Jupiter kilns easy to move, set up and disassemble for maintenance or for loading.

TOTALLY SEPARATE

- Sections are completely separate from the control panel.
- Each section has its own plug that plugs into a special receptacle in the control panel.
- This makes it easy to disconnect the control panel and send it to the factory for expert service if ever necessary.

EXPANDING AND CONTRACTING THE SIZE

Because of the unusual ease of assembling and disassembling Jupiter kilns, some people have used this feature to expand or contract firing capacity as needed. This can be useful for firing small loads while still maintaining a larger firing capacity. It can also be useful for loading the kiln.

The 22.3", 23.3", and 28" diameter Jupiter kilns (10-sided and 12-sided) all come with the standard spring loaded counterbalance system for the lid. This attaches to either three rings or two rings and the kiln bottom.

If you do want to adjust the size of the kiln you will need to remove the hinge (not too difficult).

PULL-APART OPTION

To get around the above issues we offer a variation in our Jupiter line, which is meant just for those people who definitely want to assemble and disassemble their kilns often.

This option consists of not putting a hinge on the kiln at all, having four handles on the top, and mounting the control panel on a floor stand like we do on the DaVinci control panels. The sections are not tied together. We provide 45" long cords on all the sections.

CONTROL CONSIDERATIONS

The DynaTrol is easily programmable to allow for one, two, or three zone operation. If you had a three section kiln and wanted to fire the kiln with just two sections, you would simply plug the two sections into two of the receptacles on the panel and program the DynaTrol for two-zone operation.

If you anticipate making the kiln larger, you should special order a larger control panel (with the proper number of zones).

You can see the price differential between a panel with different numbers of circuits in our parts list. The differential between the two panels is added to the price of the new kiln. For instance, if you are buying a JD230 three circuit panel with a JD245 five circuit panel you would subtract the price of the Jupiter three circuit panel from the price of the Jupiter five circuit panel and add this difference to the price of the kiln.

If you are anticipating changing a JD230 to a JD236 or JD245 you will need to order a larger panel up front.

This gets a bit more complicated if you are getting or planning to get a powered bottom with an automatic kiln. This is because the wiring for the powered bottom is slightly different on automatic kilns (i.e. where it gets its control output from) and you would not plug a regular section into the powered bottom circuit or vice-versa. Consult factory if you have specific questions.

Electrical Specifications for JD1800 SERIES

Model Numbers	Part Number for 2.5" Brick	Part Number for 3" Brick	Volt/Phase	Watts	Amps	Wire Size	Fuse Size	Power Connection
JD18-240 / JD18-3-240	K-A-180H/31	K-A-180D/31	240/1P	5,520	23.0	10 ga	30 Amps	6-50 Cordset
JD18-240-3P / JD18-3-240-3P	K-A-180H/32	K-A-180D/32	240/3P	5,520	19.9	12 ga	25 Amps	15-50 Cordset
JD18-208 / JD18-3-208	K-A-180H/21	K-A-180D/21	208/1P	5,520	26.5	8 ga	40 Amps	6-50 Cordset
JD18-208-3P / JD18-3-208-3P	K-A-180H/22	K-A-180D/22	208/3P	5,520	23.0	10 ga	30 Amps	15-50 Cordset
JD18X-240 / JD18X-3-240	K-A-18XH/31	K-A-18XD/31	240/1P	8,280	34.5	6 ga	50 Amp	6-50 Cordset
JD18X-240-3P / JD18X-3-240-3P	K-A-18XH/32	K-A-18XD/32	240/3P	8,280	19.9	12 ga	25 Amp	15-50 Cordset
JD18X-208 / JD18X-3-208	K-A-18XH/21	K-A-18XD/21	208/1P	8,280	39.8	6 ga	50 Amp	6-50 Cordset
JD18X-208-3P / JD18X-3-208-3P	K-A-18XH/22	K-A-18XD/22	208/3P	8,280	23.0	10 ga	30 Amp	15-50 Cordset
WORLD VOLTAGES								
JD18-220 / JD18-3-220	K-A-180H/41	K-A-180D/41	220/1P	5,520	25.1	8 ga	40 Amp	Direct Wire
JD18-380-3P / JD18-3-380-3PY	K-A-180H/52	K-A-180D/52	380/3PY	5,520	12.5	14 ga	20 Amp	Direct Wire
JD18X-220 / JD18X-3-220	K-A-18XH/41	K-A-18XD/41	220/1P	8,280	37.6	6 ga	50 Amp	Direct Wire
JD18X-380-3P/JD18X-3-380-3PY	K-A-18XH/52	K-A-18XD/52	380/3PY	8,280	12.5	14 ga	20 Amp	Direct Wire

MET UL499 Listing: All models are c-MET-us listed to UL499 standard.

Cone Rating: All JD18 models are rated to Cone 10.

Wiring Diagrams: See the **Electrical Tab** for each kiln model to get the wiring diagram for each voltage.

Power connection: A six foot cord with a 50 amp NEMA 6-50 for single phase units or a 15-50 plug for 3 phase units is included. (No neutral is necessary). World voltage kilns do not include a cord - they are direct wired. All kilns may be direct wired.

Optional 30 Amp Cord for Single Phase JD18 and JD18-3: The standard NEMA 6-50 amp plug can be changed to a NEMA 14-30 or NEMA 6-30 at no charge. A NEMA 10-30 is available for a small charge.

Elements: All elements are of equal resistance value. JD1800 kilns have two elements per kiln section. All Jupiter kilns with the Quad option feature two elements in four rows.

Other voltages for any country in the world are available. Examples are 200V/3 Phase Delta, 220V/3 Phase Delta, 415V/3 Phase Wye and 400V/3 Phase Wye. CE Listing available in some countries. See 380 Volt diagrams for electrical specifications for 400V/3 Phase Wye and 415V/3 Phase Wye.

Moving and installation: The kiln comes assembled but can be quickly disassembled and reassembled to move through any door or up stairs. It comes packed in a skidded carton with secure foam-in-place packaging.

Dimension & Weight Specifications for JD1800 SERIES

Model Number	Inside Dimensions	Cubic Feet	Brick Thick	Furniture Kit	Furn Kit Part No.	Outside Dimensions	Shipping Dimensions (w Kit and Vent)	Ship Weight Kiln Only	Ship Wght Kiln/Kit/Vent
JD18	17.5"D x 18"H	2.6	2.5"	(1) 15.5" full, (4) half	H-J-K180/00	31" W x 55" H x 33" D	48" W x 51" H x 40" D	215 LBS	265 LBS
JD18-3	16.5"D x 18"H	2.5	3"	(1) 15" full, (4) half	H-J-K180/30	31" W x 55" H x 33" D	48" W x 52" H x 40" D	240 LBS	290 LBS
JD18X	17.5"D x 27"H	3.9	2.5"	(2) 15.5" full, (4) half	H-J-K18X/00	31" W x 64" H x 33" D	48" W x 60" H x 40" D	265 LBS	325 LBS
JD18X-3	16.5"D x 27"H	3.7	3"	(2) 15" full, (4) half	H-J-K18X/30	31" W x 64" H x 33" D	48" W x 61" H x 40" D	290 LBS	350 LBS
METRIC DIMENSIONS (CM, LITERS & KG)									
JD18	44.5 D x 45.7 H	74	6.35	(1) 39.4 full, (4) half	H-J-K180/00	79 W x 139 H x 84 D	122 W x 130 H x 102 D	98 KG	121 KG
JD18-3	41.9 D x 45.7 H	71	7.62	(1) 38.1 full, (4) half	H-J-K180/30	79 W x 139 H x 84 D	122 W x 133 H x 102 D	109 KG	132 KG
JD18X	44.5 D x 68.6 H	111	6.35	(2) 39.4 full, (4) half	H-J-K18X/00	79 W x 150 H x 84 D	122 W x 153 H x 102 D	121 KG	148 KG
JD18X-3	41.9 D x 68.6 H	105	7.62	(2) 38.1 full, (4) half	H-J-K18X/30	79 W x 150 H x 84 D	122 W x 155 H x 102 D	132 KG	159 KG

MORE: See each model page on hotkilns.com to download PDF General Dimension Drawings for more outside and inside dimensions, minimum space requirements, BTU ventilation requirements, and kiln weight. See the Shipping Tab on the model page for complete shipping dimension and shipping weight information.

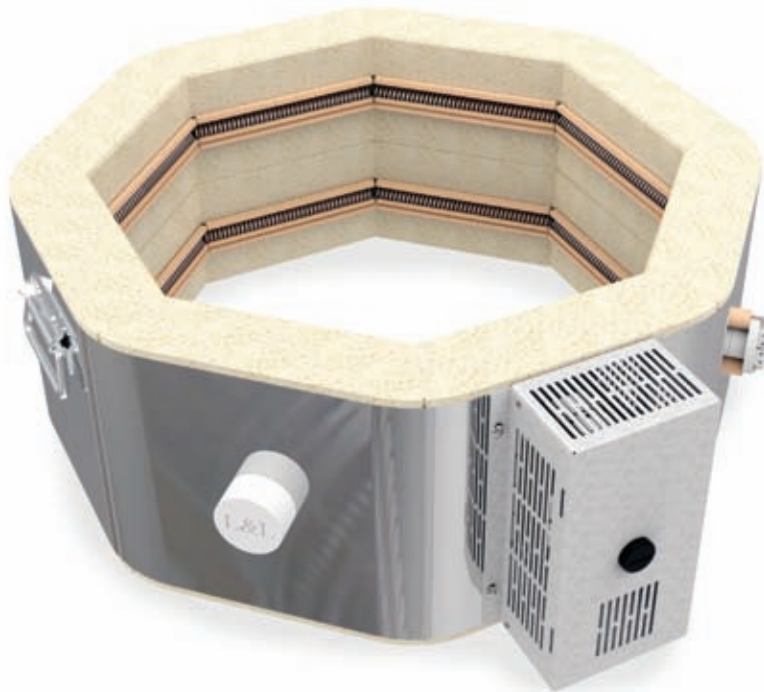

JD18

Temperature Rating: Cone 10

Volume: 2.6 Cubic Feet

Brick Thickness: 2.5" Brick

Inside: 17.5" Diam x 18" High

Outside Dimensions: 31" W x 55" H x 33" D

Shipping Dim with Vent & Furn Kit: 48" W x 51" H x 40" D

Ship Weight (Kiln): 215 LBS

Ship Weight (Kiln, Vent & Furn Kit): 265 LBS



FURNITURE KIT FOR JD18

Part Number: H-J-K180/00

Includes: Two 15-1/2" Full Round Shelves and Four 15-1/2" Half Round Shelves (5/8" thick), One small post kit with 4 each 1/2", 1", 2", 4", and 6" square posts, and one pair heat resistant gloves.



JD18-3

Temperature Rating: Cone 10

Volume: 2.5 Cubic Feet

Brick Thickness: 3" Brick

Inside: 16.5" Diam x 18" High

Outside Dimensions: 31" W x 55" H x 33" D

Shipping Dim with Vent & Furn Kit: 48" W x 52" H x 40" D

Ship Weight (Kiln): 240 LBS

Ship Weight (Kiln, Vent & Furn Kit): 290 LBS



FURNITURE KIT FOR JD18-3

Part Number: H-J-K180/30

Includes: One 15" Full Round Shelf and Four 15" Half Round Shelves (5/8" thick), One small post kit with 4 each 1/2", 1", 2", 4", and 6" square posts, and one pair heat resistant gloves.



JD18X

Temperature Rating: Cone 10

Volume: 3.9 Cubic Feet

Brick Thickness: 2.5" Brick

Inside: 17.5" Diam x 27" High

Outside Dimensions: 31" W x 64" H x 33" D

Shipping Dim with Vent & Furn Kit: 48" W x 60" H x 40" D

Ship Weight (Kiln): 265 LBS

Ship Weight (Kiln, Vent & Furn Kit): 321 LBS



FURNITURE KIT FOR JD18X

Part Number: H-J-K18X/00

Includes: Two 15-1/2" Full Round Shelves and Four 15-1/2" Half Round Shelves (5/8" thick), One post kit with 6 each 1/2", 1", 2", 4", 6", and 8" square posts, and one pair heat resistant gloves.

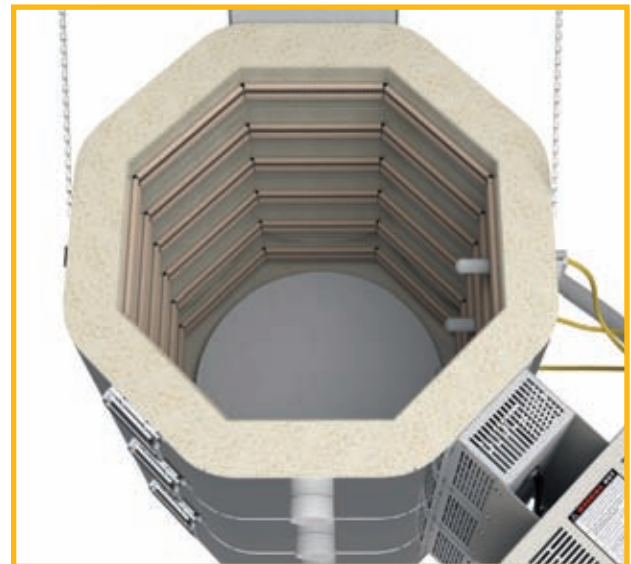

JD18X-3

Temperature Rating: Cone 10

Volume: 3.7 Cubic Feet

Brick Thickness: 3" Brick

Inside: 16.5" Diam x 27" High

Outside Dimensions: 31" W x 64" H x 33" D

Shipping Dim with Vent & Furn Kit: 48" W x 61" H x 40" D

Ship Weight (Kiln): 290 LBS

Ship Weight (Kiln, Vent & Furn Kit): 350 LBS

FURNITURE KIT FOR JD18X-3

Part Number: H-J-K18X/30

Includes: Two 15" Full Round Shelves and Four 15" Half Round Shelves (5/8" thick), One post kit with 6 each 1/2", 1", 2", 4", 6", and 8" square posts, and one pair heat resistant gloves.

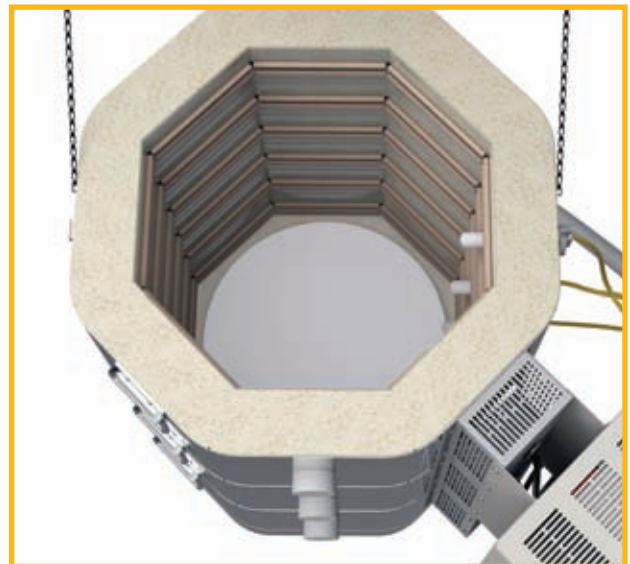

Electrical Specifications for JD2300 SERIES (USA)

Model Number	Power Bottom	Part Number for 2.5" Brick	Part Number for 3" Brick	Volt/Phase	Watts	Amps	Wire Size	Fuse Size	Power Connection
JD23V-240 / JD23V-3-240	No	K-A-230H/31	K-A-230D/31	240/1P	7,030	29.3	8 ga	40	6-50 Cordset
JD23V-240-3P / JD23V-3-240-3P	No	K-A-230H/32	K-A-230D/32	240/3P	7,030	25.4	8 ga	40	15-50 Cordset
JD23V-208 / JD23V-3-208	No	K-A-230H/21	K-A-230D/21	208/1P	6,096	29.3	8 ga	40	6-50 Cordset
JD23V-208-3P / JD23V-3-208-3P	No	K-A-230H/22	K-A-230D/22	208/3P	6,096	25.4	8 ga	40	15-50 Cordset
JD23V-PB-240 / JD23V-3-PB-240	Yes	K-A-230P/31	K-A-230B/31	240/1P	8,800	36.6	6 ga	50	6-50 Cordset
JD23V-PB-240-3P / JD23V-3-PB-240-3P	Yes	K-A-230P/32	K-A-230B/32	240/3P	8,800	25.4	8 ga	40	15-50 Cordset
JD23V-PB-208 / JD23V-3-PB-208	Yes	K-A-230P/21	K-A-230B/21	208/1P	7,620	36.6	6 ga	50	6-50 Cordset
JD23V-PB-208-3P / JD23V-3-PB-208-3P	Yes	K-A-230P/22	K-A-230B/22	208/3P	7,620	25.4	8 ga	40	15-50 Cordset
JD230V-240 / JD230V-3-240	No	K-A-231H/31	K-A-231D/31	240/1P	10,554	43.9	6 ga	60	6-50 Cordset
JD230V-240-3P / JD230V-3-240-3P	No	K-A-231H/32	K-A-231D/32	240/3P	10,554	25.4	8 ga	40	15-50 Cordset
JD230V-208 / JD230V-3-208	No	K-A-231H/21	K-A-231D/21	208/1P	9,144	44.0	6 ga	60	6-50 Cordset
JD230V-208-3P / JD230V-3-208-3P	No	K-A-231H/22	K-A-231D/22	208/3P	9,144	25.4	8 ga	40	15-50 Cordset
JD230V-PB-240 / JD230V-3-PB-240	Yes	K-A-231P/31	K-A-231B/31	240/1P	12,303	51.3	4 ga	70	Direct Wire
JD230V-PB-240-3P / JD230V-3-PB-240-3P	Yes	K-A-231P/32	K-A-231B/32	240/3P	12,303	31.9	8 ga	40	15-50 Cordset
JD230V-PB-208 / JD230V-3-PB-208	Yes	K-A-231P/21	K-A-231B/21	208/1P	10,668	51.3	4 ga	70	Direct Wire
JD230V-PB-208-3P / JD230V-3-PB-208-3P	Yes	K-A-231P/22	K-A-231B/22	208/3P	10,668	31.9	8 ga	40	15-50 Cordset
JD236V-240 / JD236V-3-240	No	K-A-236H/31	K-A-236D/31	240/1P	14,060	58.6	3 ga	80	Direct Wire
JD236V-240-3P / JD236V-3-240-3P	No	K-A-236H/32	K-A-236D/32	240/3P	14,060	38.8	6 ga	50	15-50 Cordset
JD236V-208 / JD236V-3-208	No	K-A-236H/21	K-A-236D/21	208/1P	12,192	58.6	3 ga	80	Direct Wire
JD236V-208-3P / JD236V-3-208-3P	No	K-A-236H/22	K-A-236D/22	208/3P	12,192	38.8	6 ga	50	15-50 Cordset
JD236V-PB-240 / JD236V-3-PB-240	Yes	K-A-236P/31	K-A-236B/31	240/1P	15,817	65.9	2 ga	90	Direct Wire
JD236V-PB-240-3P / JD236V-3-PB-240-3P	Yes	K-A-236P/32	K-A-236B/32	240/3P	15,817	44.6	6 ga	60	15-50 Cordset
JD236V-PB-208 / JD236V-3-PB-208	Yes	K-A-236P/21	K-A-236B/21	208/1P	13,716	65.9	2 ga	90	Direct Wire
JD236V-PB-208-3P / JD236V-3-PB-208-3P	Yes	K-A-236P/22	K-A-236B/22	208/3P	13,716	44.6	6 ga	60	Direct Wire
JD245V-240 / JD245V-3-240	No	K-A-245H/31	K-A-245D/31	240/1P	17,575	73.2	1 ga	100	Direct Wire
JD245V-240-3P / JD245V-3-240-3P	No	K-A-245H/32	K-A-245D/32	240/3P	17,575	50.7	4 ga	70	Direct Wire
JD245V-208 / JD245V-3-208	No	K-A-245H/21	K-A-245D/21	208/1P	15,240	73.3	1 ga	100	Direct Wire
JD245V-208-3P / JD245V-3-208-3P	No	K-A-245H/22	K-A-245D/22	208/3P	15,240	50.8	4 ga	70	Direct Wire
JD245V-PB-240 / JD245V-3-PB-240	Yes	K-A-245P/31	K-A-245B/31	240/1P	19,333	80.6	1 ga	110	Direct Wire
JD245V-PB-240-3P / JD245V-3-PB-240-3P	Yes	K-A-245P/32	K-A-245B/32	240/3P	19,333	50.7	4 ga	70	Direct Wire
JD245V-PB-208 / JD245V-3-PB-208	Yes	K-A-245P/21	K-A-245B/21	208/1P	16,764	80.6	1 ga	110	Direct Wire
JD245V-PB-208-3P / JD245V-3-PB-208-3P	Yes	K-A-245P/22	K-A-245B/22	208/3P	16,764	50.8	4 ga	70	Direct Wire

MET UL499 Listing: All models are c-MET-us listed to UL499 standard.

Wiring Diagrams: See the **Electrical Tab** for each kiln model to get the wiring diagram for each voltage.

Power connection: A six foot cord with a 50 amp NEMA 6-50 for single phase units or a 15-50 plug for 3 phase units is included. (No neutral is necessary). All kilns may be direct wired.

Elements: All elements are of equal resistance value. JD2300 kilns have two elements per kiln section. Powered Bottom adds one element. All Jupiter kilns with the Quad option feature two elements in four rows.

Electrical Specifications for JD2300 SERIES (World)

Model Number	Power Bottom	Part Number for 2.5" Brick	Part Number for 3" Brick	Volt/Phase	Watts	Amps	Wire Size	Fuse Size	Power Connection
JD23V-220 / JD23V-3-220	No	K-A-230H/41	K-A-230D/41	220V/1P	6,450	29.3	8 ga	40	Direct Wire
JD23V-380-3PY / JD23V-3-380-3PY	No	K-A-230H/52	K-A-230D/52	380/3PY	6,450	14.7	14 ga	20	Direct Wire
JD23V-PB-220 / JD23V-3-PB-220	Yes	K-A-230P/41	K-A-230B/41	220V/1P	8,063	36.7	6 ga	50	Direct Wire
JD23V-PB-380-3PY / JD23V-3-PB-380-3PY	Yes	K-A-230P/52	K-A-230B/52	380/3PY	8,063	14.7	14 ga	20	Direct Wire
JD230V-220 / JD230V-3-220	No	K-A-231H/41	K-A-231D/41	220V/1P	9,675	44.0	6 ga	60	Direct Wire
JD230V-380-3PY / JD230V-3-380-3PY	No	K-A-231H/52	K-A-231D/52	380/3PY	9,675	14.7	14 ga	20	Direct Wire
JD230V-PB-220 / JD230V-3-PB-220	Yes	K-A-231P/41	K-A-231B/41	220V/1P	11,288	51.3	4 ga	70	Direct Wire
JD230V-PB-380-3PY / JD230V-3-PB-380-3PY	Yes	K-A-231P/52	K-A-231B/52	380/3PY	11,288	22.0	10 ga	30	Direct Wire
JD236V-220 / JD236V-3-220	No	K-A-236H/41	K-A-236D/41	220V/1P	12,900	58.6	3 ga	80	Direct Wire
JD236V-380-3PY / JD236V-3-380-3PY	No	K-A-236H/52	K-A-236D/52	380/3PY	12,900	29.3	8 ga	40	Direct Wire
JD236V-PB-220 / JD236V-3-PB-220	Yes	K-A-236P/41	K-A-236B/41	220V/1P	14,512	66.0	2 ga	90	Direct Wire
JD236V-PB-380-3PY / JD236V-3-PB-380-3PY	Yes	K-A-236P/52	K-A-236B/52	380/3PY	14,512	29.3	8 ga	40	Direct Wire
JD245V-220 / JD245V-3-220	No	K-A-245H/41	K-A-245D/41	220V/1P	16,125	73.3	1 ga	100	Direct Wire
JD245V-380-3PY / JD245V-3-380-3PY	No	K-A-245H/52	K-A-245D/52	380/3PY	16,125	29.3	8 ga	40	Direct Wire
JD245V-PB-220 / JD245V-3-PB-220	Yes	K-A-245P/41	K-A-245B/41	220V/1P	17,738	80.6	1 ga	110	Direct Wire
JD245V-PB-380-3PY / JD245V-3-PB-380-3PY	Yes	K-A-245P/52	K-A-245B/52	380/3PY	17,738	29.3	8 ga	40	Direct Wire

MET UL499 Listing: All models are c-MET-us listed to UL499 standard.

Wiring Diagrams: See the **Electrical Tab** for each kiln model to get the wiring diagram for each voltage.

Power connection: World voltage kilns do not include a cord - they are direct wired.

Elements: All elements are of equal resistance value. JD2300 kilns have two elements per kiln section. Powered Bottom adds one element. All Jupiter kilns with the Quad option feature two elements in four rows.

Other voltages for any country in the world are available. Examples are 200V/3 Phase Delta, 220V/3 Phase Delta, 415V/3 Phase Wye and 400V/3 Phase Wye. CE Listing available in some countries. See 380 Volt diagrams for electrical specifications for 400V/3 Phase Wye and 415V/3 Phase Wye.

Dimension & Weight Specifications for JD2300 SERIES

Model Number	Inside Dimensions	Cubic Feet	Brick Thick	Furniture Kit	Furn Kit Part No.	Outside Dimensions	Shipping Dimensions (w Kit and Vent)	Ship Weight Kiln Only	Ship Wght Kiln/Kit/Vent
JD23V	23-3/8"D x 18"H	4.7	2-1/2"	(1) 21" full, (4) half	H-J-K230/00	30" W x 59" H x 43" D	48" W x 51" H x 40" D	315 LBS	395 LBS
JD23V-3	22-3/8"D x 18"H	4.5	3"	(1) 20" full, (4) half	H-J-K230/30	30" W x 59" H x 43" D	48" W x 52" H x 40" D	330 LBS	405 LBS
JD230V	23-3/8"D x 27"H	7.0	2-1/2"	(2) 21" full, (4) half	H-J-K23X/00	30" W x 68" H x 43" D	48" W x 60" H x 40" D	365 LBS	465 LBS
JD230V-3	22-3/8"D x 27"H	6.7	3"	(2) 20" full, (4) half	H-J-K23X/30	30" W x 68" H x 43" D	48" W x 61" H x 40" D	385 LBS	475 LBS
JD236V	23-3/8"D x 36"H	9.4	2-1/2"	(3) 21" full, (4) half	H-J-K236/00	30" W x 74" H x 43" D	48" W x 60" H x 40" D	425 LBS	540 LBS
JD236V-3	22-3/8"D x 36"H	8.9	3"	(3) 20" full, (4) half	H-J-K236/30	30" W x 74" H x 43" D	48" W x 61" H x 40" D	445 LBS	550 LBS
JD245V	23-3/8"D x 45"H	11.8	2-1/2"	(4) 21" full, (4) half	H-J-K245/00	30" W x 86" H x 43" D	48" W x xx" H x 40" D	490 LBS	625 LBS
JD245V-3	22-3/8"D x 45"H	11.1	3"	(4) 20" full, (4) half	H-J-K245/30	30" W x 86" H x 43" D	48" W x xx" H x 40" D	520 LBS	645 LBS
METRIC DIMENSIONS (CM, LITERS & KG)									
JD23V	59.2 D x 45.7 H	134	6.35	(1) 53.3 full, (4) half	H-J-K230/00	76 W x 150 H x 109 D	122 W x 130 H x 102 D	143 KG	180 KG
JD23V-3	56.6 D x 45.7 H	128	7.62	(1) 50.8 full, (4) half	H-J-K230/00	76 W x 150 H x 109 D	122 W x 133 H x 102 D	150 KG	184 KG
JD230V	59.2 D x 68.6 H	199	6.35	(2) 53.3 full, (4) half	H-J-K23X/00	76 W x 173 H x 109 D	122 W x 153 H x 102 D	166 KG	211 KG
JD230V-3	56.6 D x 68.6 H	190	7.62	(2) 50.8 full, (4) half	H-J-K23X/30	76 W x 173 H x 109 D	122 W x 155 H x 102 D	175 KG	216 KG
JD236V	59.2 D x 91.4 H	267	6.35	(3) 53.3 full, (4) half	H-J-K236/00	76 W x 188 H x 109 D	122 W x 153 H x 102 D	193 KG	209 KG
JD236V-3	56.6 D x 91.4 H	253	7.62	(3) 50.6 full, (4) half	H-J-K236/30	76 W x 188 H x 109 D	122 W x 155 H x 102 D	202 KG	220 KG
JD245V	59.2 D x 114.3 H	335	6.35	(4) 53.3 full, (4) half	H-J-K245/00	76 W x 218 H x 109 D	122 W x 216 H x 102 D	222 KG	284 KG
JD245V-3	56.8 D x 114.3 H	315	7.62	(4) 50.8 full, (4) half	H-J-K245/30	76 W x 218 H x 109 D	122 W x 216 H x 102 D	236 KG	293 KG

MORE: See each model page on hotkilns.com to download PDF General Dimension Drawings for more outside and inside dimensions, minimum space requirements, BTU ventilation requirements, and kiln weight. See the Shipping Tab on the model page for complete shipping dimension and shipping weight information.

General Dimension Drawings: See each model page on hotkilns.com to download PDF drawings.

Moving and installation: The kiln comes assembled but can be quickly disassembled and reassembled to move through any door or up stairs. It comes packed in a skidded carton with secure foam-in-place packaging.

Shipping Dimensions: See website for shipping dimensions with various combinations of options.

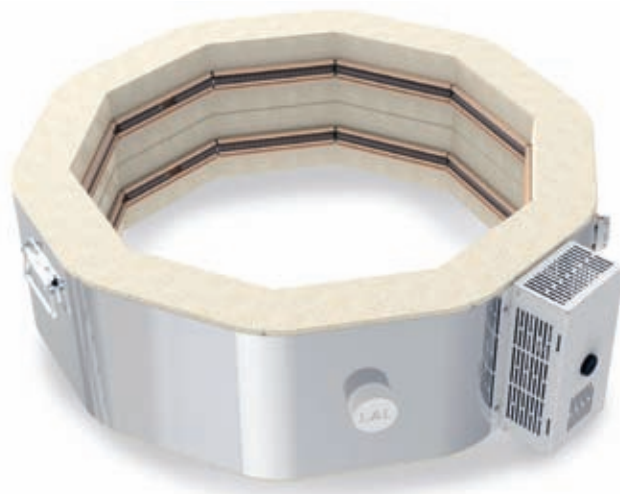

JD23

Temperature Rating: Cone 10

Volume: 4.7 Cubic Feet

Brick Thickness: 2.5" Brick

Inside: 23-3/8" Diam x 18" High

Outside Dimensions: 30" W x 59" H x 43" D

Shipping Dim with Vent & Furn Kit: 48" W x 51" H x 40" D

Ship Weight (Kiln): 315 LBS

Ship Weight (Kiln, Vent & Furn Kit): 395 LBS



FURNITURE KIT FOR JD23

Part Number: H-J-K230/00

Includes: One 21" Full Round Shelf and Four 21" Half Round Shelves (3/4" thick), One post kit with 6 each 1/2", 1", 2", 4", 6", and 8" square posts, and one pair heat resistant gloves.

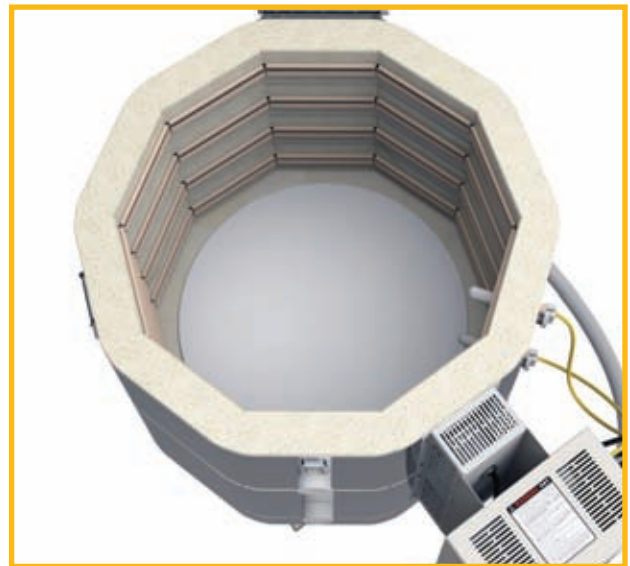

JD23-3

Temperature Rating: Cone 10

Volume: 4.5 Cubic Feet

Brick Thickness: 3" Brick

Inside: 22-3/8" Diam x 18" High

Outside Dimensions: 30" W x 59" H x 43" D

Shipping Dim with Vent & Furn Kit: 48" W x 52" H x 40" D

Ship Weight (Kiln): 330 LBS

Ship Weight (Kiln, Vent & Furn Kit): 405 LBS



FURNITURE KIT FOR JD23-3

Part Number: H-J-K230/30

Includes: One 20" Full Round Shelf and Four 20" Half Round Shelves (3/4" thick), One post kit with 6 each 1/2", 1", 2", 4", 6", and 8" square posts, and one pair heat resistant gloves.



JD230

Temperature Rating: Cone 10

Volume: 7 Cubic Feet

Brick Thickness: 2.5" Brick

Inside: 23-3/8" Diam x 27" High

Outside Dimensions: 30" W x 68" H x 43" D

Shipping Dim with Vent & Furn Kit: 48" W x 60" H x 40" D

Ship Weight (Kiln): 365 LBS

Ship Weight (Kiln, Vent & Furn Kit): 465 LBS



FURNITURE KIT FOR JD230

Part Number: H-J-K23X/00

Includes: Two 21" Full Round Shelves and Four 21" Half Round Shelves (3/4" thick), One post kit with 6 each 1/2", 1", 2", 4", 6", and 8" square posts, and one pair heat resistant gloves.



JD230-3

Temperature Rating: Cone 10

Volume: 6.7 Cubic Feet

Brick Thickness: 3" Brick

Inside: 22-3/8" Diam x 27" High

Outside Dimensions: 30" W x 68" H x 43" D

Shipping Dim with Vent & Furn Kit: 48" W x 61" H x 40" D

Ship Weight (Kiln): 385 LBS

Ship Weight (Kiln, Vent & Furn Kit): 475 LBS

FURNITURE KIT FOR JD230-3

Part Number: H-J-K23X/30

Includes: Two 20" Full Round Shelves and Four 20" Half Round Shelves (3/4" thick), One post kit with 6 each 1/2", 1", 2", 4", 6", and 8" square posts, and one pair heat resistant gloves.

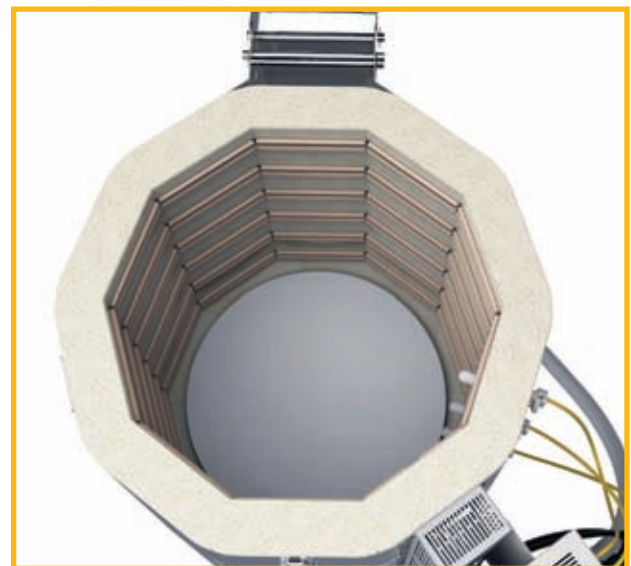

JD236

Temperature Rating: Cone 10

Volume: 9.4 Cubic Feet

Brick Thickness: 2.5" Brick

Inside: 23-3/8" Diam x 36" High

Outside Dimensions: 30" W x 74" H x 43" D

Shipping Dim with Vent & Furn Kit: 48" W x 61" H x 40" D

Ship Weight (Kiln): 425 LBS

Ship Weight (Kiln, Vent & Furn Kit): 540 LBS

FURNITURE KIT FOR JD236

Part Number: H-J-K236/00

Includes: Three 21" Full Round Shelves and Four 21" Half Round Shelves (3/4" thick), One post kit with 6 each 1/2", 1", 2", 4", 6", and 8" square posts, and one pair heat resistant gloves.

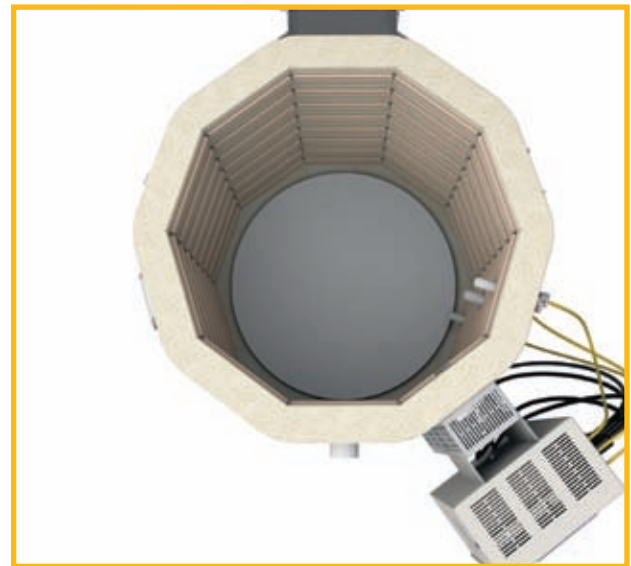

JD236-3

Temperature Rating: Cone 10

Volume: 8.9 Cubic Feet

Brick Thickness: 3" Brick

Inside: 22-3/8" Diam x 36" High

Outside Dimensions: 30" W x 74" H x 43" D

Shipping Dim with Vent & Furn Kit: 48" W x 70" H x 40" D

Ship Weight (Kiln): 445 LBS

Ship Weight (Kiln, Vent & Furn Kit): 550 LBS



FURNITURE KIT FOR JD236-3

Part Number: H-J-K236/30

Includes: Three 20" Full Round Shelves and Four 20" Half Round Shelves (3/4" thick), One post kit with 6 each 1/2", 1", 2", 4", 6", and 8" square posts, and one pair heat resistant gloves.



JD245

Temperature Rating: Cone 10

Volume: 11.8 Cubic Feet

Brick Thickness: 2.5" Brick

Inside: 23-3/8" Diam x 48" High

Outside Dimensions: 30" W x 86" H x 43" D

Shipping Dim with Vent & Furn Kit: 48" W x 85" H x 40" D

Ship Weight (Kiln): 590 LBS

Ship Weight (Kiln, Vent & Furn Kit): 625 LBS



FURNITURE KIT FOR JD245

Part Number: H-J-K245/00

Includes: Four 21" Full Round Shelves and Four 21" Half Round Shelves (3/4" thick), One post kit with 6 each 1/2", 1", 2", 4", 6", and 8" square posts, and one pair heat resistant gloves.

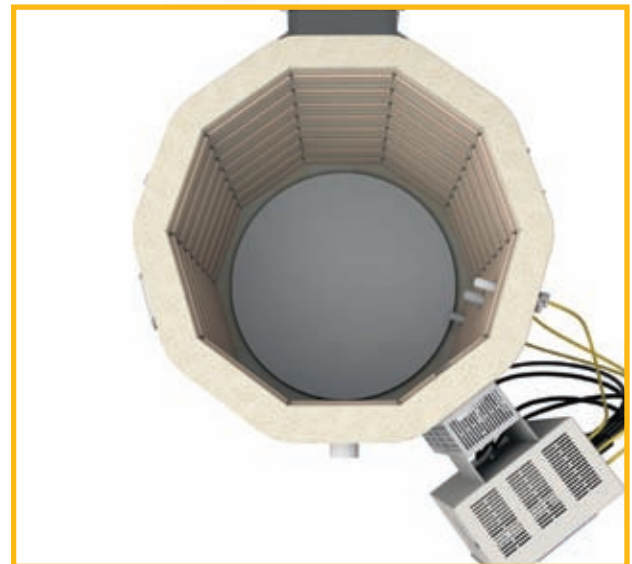

JD245-3

Temperature Rating: Cone 10

Volume: 11.1 Cubic Feet

Brick Thickness: 3" Brick

Inside: 22-3/8" Diam x 45" High

Outside Dimensions: 30" W x 86" H x 43" D

Shipping Dim with Vent & Furn Kit: 48" W x 85" H x 40" D

Ship Weight (Kiln): 490 LBS

Ship Weight (Kiln, Vent & Furn Kit): 645 LBS



FURNITURE KIT FOR JD245-3

Part Number: H-J-K245/30

Includes: Four 20" Full Round Shelves and Four 20" Half Round Shelves (3/4" thick), One post kit with 6 each 1/2", 1", 2", 4", 6", and 8" square posts, and one pair heat resistant gloves.

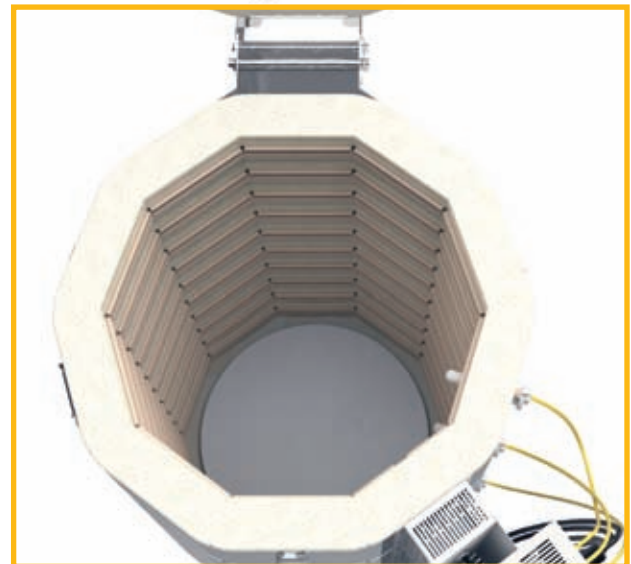

Electrical Specifications for JD2900 SERIES

Standard Models							Powered Bottom Models					
Model Number	Part Number	Volt/Phase	Watts	Amps	Wire Size	Fuse Size	Model Number	Part Number	Watts	Amps	Wire Size	Fuse Size
JD2918-3-240	K-A-291D/31	240/1P	9,120	38.0	6 ga	50	JD2918-3-PB-240	K-A-291B/31	12,162	50.7	4 ga	70
JD2918-3-240-3P	K-A-291D/32	240/3P	9,120	32.9	6 ga	50	JD2918-3-PB-240-3P	K-A-291B/32	12,162	32.9	6 ga	50
JD2918-3-208	K-A-291D/21	208/1P	8,320	40.0	6 ga	50	JD2918-3-PB-208	K-A-291B/21	11,095	53.3	4 ga	70
JD2918-3-208-3P	K-A-291D/22	208/3P	8,320	34.6	6 ga	50	JD2918-3-PB-208-3P	K-A-291B/22	11,095	34.7	6 ga	50
JD2927-3-240	K-A-292D/31	240/1P	13,680	57.0	3 ga	80	JD2927-3-PB-240	K-A-292B/31	16,720	69.7	2 ga	90
JD2927-3-240-3P	K-A-292D/32	240/3P	13,680	32.9	6 ga	50	JD2927-3-PB-240-3P	K-A-292B/32	16,720	44.3	6 ga	60
JD2927-3-208	K-A-292D/21	208/1P	12,480	60.0	3 ga	80	JD2927-3-PB-208	K-A-292B/21	15,253	73.3	1 ga	100
JD2927-3-208-3P	K-A-292D/22	208/3P	12,480	34.6	6 ga	50	JD2927-3-PB-208-3P	K-A-292B/22	15,253	46.7	6 ga	60
JD2936-3-240	K-A-293D/31	240/1P	18,240	76.0	1 ga	100	JD2936-3-PB-240	K-A-293B/31	21,282	88.7	1/0	125
JD2936-3-240-3P	K-A-293D/32	240/3P	18,240	50.3	4 ga	70	JD2936-3-PB-240-3P	K-A-293B/32	21,282	60.4	3 ga	80
JD2936-3-208	K-A-293D/21	208/1P	16,640	80.0	1 ga	100	JD2936-3-PB-208	K-A-293B/21	19,415	93.3	1/0	125
JD2936-3-208-3P	K-A-293D/22	208/3P	16,640	52.9	4 ga	70	JD2936-3-PB-208-3P	K-A-293B/22	19,415	63.6	3 ga	80
JD2945-3-240	K-A-294D/31	240/1P	22,800	95.0	1/0	125	JD2945-3-PB-240	K-A-294B/31	25,842	107.7	3/0	150
JD2945-3-240-3P	K-A-294D/32	240/3P	22,800	65.8	2 ga	90	JD2945-3-PB-240-3P	K-A-294B/32	25,842	65.8	2 ga	90
JD2945-3-208	K-A-294D/21	208/1P	20,800	100.0	1/0	125	JD2945-3-PB-208	K-A-294B/21	23,575	113.3	3/0	150
JD2945-3-208-3P	K-A-294D/22	208/3P	20,800	69.3	2 ga	90	JD2945-3-PB-208-3P	K-A-294B/22	23,575	69.3	2 ga	90
WORLD VOLTAGES												
JD2918-3-220	K-A-291D/41	220/1P	8,360	38.0	6 ga	50	JD2918-3-PB-220	K-A-291B/41	11,148	50.7	4 ga	70
JD2918-3-380-3PY	K-A-291D/52	380/3Y	8,360	19.0	12 ga	25	JD2918-3-PB-380-3Y	K-A-291B/52	11,148	19.0	12 ga	25
JD2927-3-220	K-A-292D/41	220/1P	12,540	57.0	3 ga	80	JD2927-3-PB-220	K-A-292B/41	15,327	69.7	2 ga	90
JD2927-3-380-3PY	K-A-292D/52	380/3Y	12,540	19.0	12 ga	25	JD2927-3-PB-380-3Y	K-A-292B/52	15,327	31.7	8 ga	40
JD2936-3-220	K-A-293D/41	220/1P	16,720	76.0	1 ga	100	JD2936-3-PB-220	K-A-293B/41	19,508	88.7	1/0	125
JD2936-3-380-3PY	K-A-293D/52	380/3Y	16,720	38.0	6 ga	50	JD2936-3-PB-380-3Y	K-A-293B/52	19,508	38.0	6 ga	50
JD2945-3-220	K-A-294D/41	220/1P	20,900	95.0	1/0	125	JD2945-3-PB-220	K-A-294B/41	23,688	107.7	3/0	150
JD2945-3-380-3PY	K-A-294D/52	380/3Y	20,900	38.0	6 ga	50	JD2945-3-PB-380-3Y	K-A-294B/52	23,688	38.0	6 ga	50

Cone/Temperature Rating: Cone 10, 2350°F, 1290°C (except JD2918-3 is rated for Cone 5, 2165°F, 1185°C)

MET UL499 Listing: All models are c-MET-us listed to UL499 standard.

Power connection: A six foot cord with a 50 amp NEMA 6-50 for single phase units or a 15-50 plug for 3 phase units is included. (No neutral is necessary). World voltage kilns do not include a cord - they are direct wired. All kilns may be direct wired.

Wiring Diagrams: See the **Electrical Tab** for each kiln model to get the wiring diagram for each voltage.

Elements: All elements are of equal resistance value. JD2900 kilns have three elements per kiln section. All Jupiter kilns with the Quad option feature two elements in four rows. Powered Bottom adds two elements.

Other voltages for any country in the world are available. Examples are 200V/3 Phase Delta, 220V/3 Phase Delta, 415V/3 Phase Wye and 400V/3 Phase Wye. CE Listing available in some countries. See 380 Volt diagrams for electrical specifications for 400V/3 Phase Wye and 415V/3 Phase Wye.

Dimension & Weight Specifications for JD2900 SERIES

Model Number	Inside Height	Cubic Feet	Furniture Kit	Furniture Kit Part No.	Outside Dimensions	Shipping Dimensions (with Kit)	Ship Weight Kiln Only	Ship Weight Kiln + Kit
JD2918-3	18"	6.8	(6) 25.5" half	H-J-K290/00	36" W x 65" H x 49" D	48" W x 61" H x 40" D	425 LBS	535 LBS
JD2927-3	27"	10.2	(8) 25.5" half	H-J-K292/00	36" W x 74" H x 49" D	48" W x 67" H x 40" D	495 LBS	630 LBS
JD2936-3	36"	13.6	(10) 25.5" half	H-J-K293/00	36" W x 83" H x 49" D	48" W x 76" H x 40" D	585 LBS	750 LBS
JD2945-3	45"	17	(12) 25.5" half	H-J-K294/00	36" W x 92" H x 49" D	48" W x 74" H x 40" D and 48" W x 56" H x 40" D	670 LBS	860 LBS
METRIC DIMENSIONS (CM, LITERS & KG)								
JD2918-3	45.7	193	(6) 64.8 half	H-J-K290/00	91 W x 165 H x 124 D	122 W x 155 H x 102 D	193 KG	243 KG
JD2927-3	68.6	289	(8) 64.8 half	H-J-K292/00	91 W x 188 H x 124 D	122 W x 171 H x 102 D	225 KG	286 KG
JD2936-3	91.4	386	(10) 64.8 half	H-J-K293/00	91 W x 211 H x 124 D	122 W x 194 H x 102 D	266 KG	341 KG
JD2945-3	114.3	482	(12) 64.8 half	H-J-K294/00	91 W x 234 H x 124 D	122 W x 188 H x 102 D and 122 W x 143 H x 102 D	304 KG	391 KG

MORE: See each model page on hotkilns.com to download PDF General Dimension Drawings for more outside and inside dimensions, minimum space requirements, BTU ventilation requirements, and kiln weight. See the Shipping Tab on the model page for complete shipping dimension and shipping weight information.

General Dimension Drawings: See each model page on hotkilns.com to download PDF drawings.

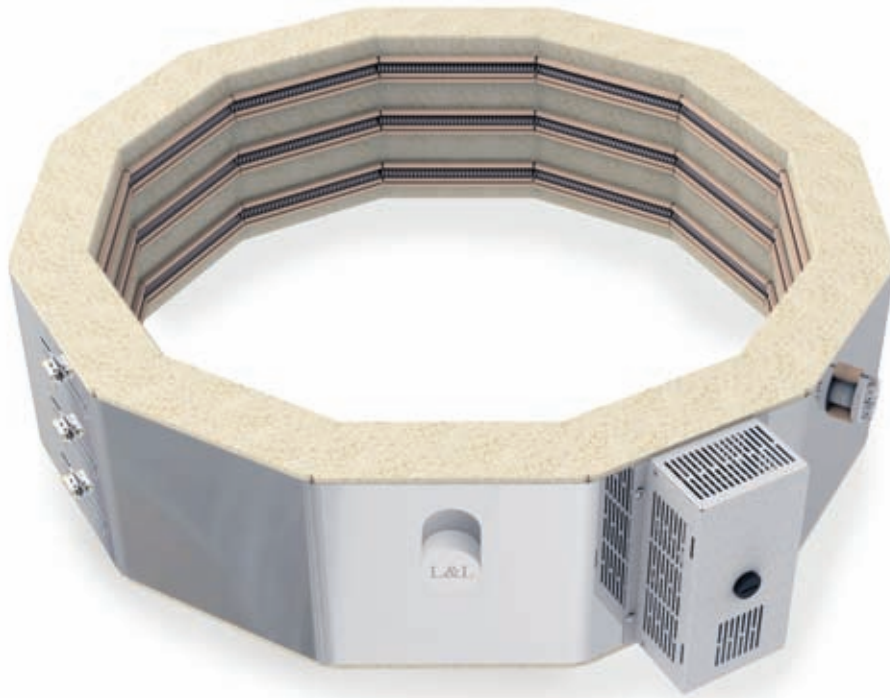

JD2918-3

Temperature Rating: Cone 10

Volume: 6.8 Cubic Feet

Brick Thickness: 3" Brick

Inside: 28" Diam x 18" High

Outside Dimensions: 36" W x 65" H x 49" D

Shipping Dim with Vent & Furn Kit: 48" W x 61" H x 40" D

Ship Weight (Kiln): 425 LBS

Ship Weight (Kiln, Vent & Furn Kit): 535 LBS



FURNITURE KIT FOR JD2918-3

Part Number: H-J-K290/00

Includes: Six 25.5" (64.8 cm) half shelves, One post kit with 6 each 1/2", 1", 2", 4", 6", and 8" square posts, and one pair heat resistant gloves.

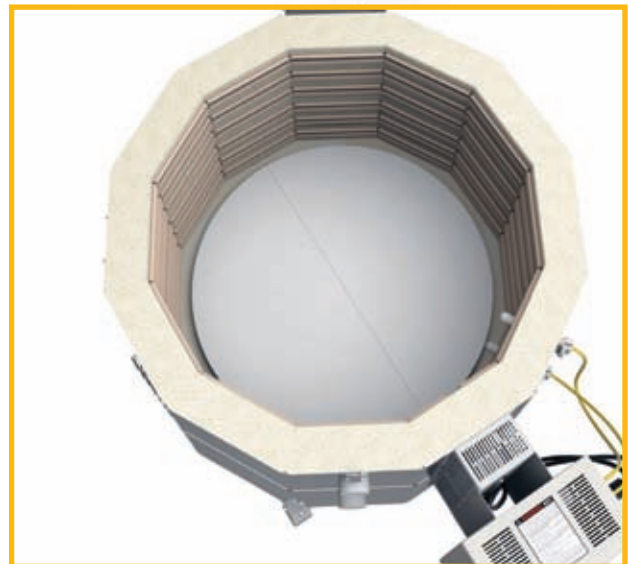

JD2927-3

Temperature Rating: Cone 10

Volume: 10.2 Cubic Feet

Brick Thickness: 3" Brick

Inside: 28" Diam x 27" High

Outside Dimensions: 36" W x 74" H x 49" D

Shipping Dim with Vent & Furn Kit: 48" W x 67" H x 40" D

Ship Weight (Kiln): 435 LBS

Ship Weight (Kiln, Vent & Furn Kit): 630 LBS



FURNITURE KIT FOR JD2927-3

Part Number: H-J-K290/00

Includes: Eight 25.5" (64.8 cm) half shelves, One post kit with 6 each 1/2", 1", 2", 4", 6", and 8" square posts, and one pair heat resistant gloves.



JD2936-3

Temperature Rating: Cone 10

Volume: 13.6 Cubic Feet

Brick Thickness: 3" Brick

Inside: 28" Diam x 36" High

Outside Dimensions: 36" W x 83" H x 49" D

Shipping Dim with Vent & Furn Kit: 48" W x 76" H x 40" D &
36" W x 20" H x 36" D

Ship Weight (Kiln): 585 LBS

Ship Weight (Kiln, Vent & Furn Kit): 750 LBS



FURNITURE KIT FOR JD2936-3

Part Number: H-J-K290/00

Includes: Ten 25.5" (64.8 cm) half shelves, One post kit with 6 each 1/2", 1", 2", 4", 6", and 8" square posts, and one pair heat resistant gloves.

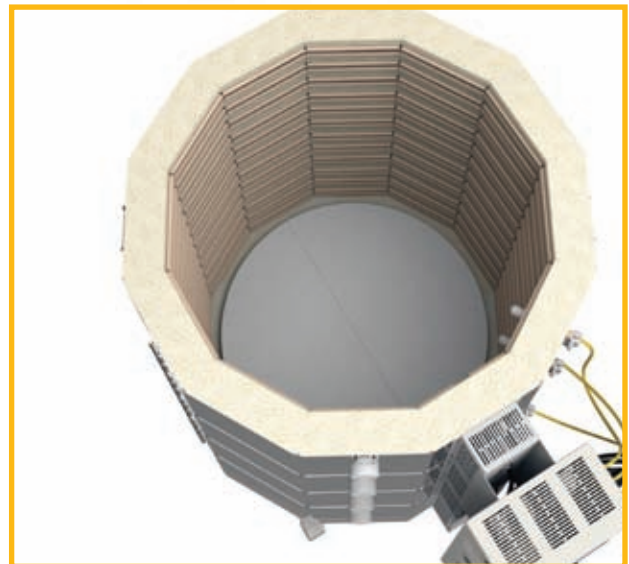

JD2945-3

Temperature Rating: Cone 10

Volume: 17 Cubic Feet

Brick Thickness: 3" Brick

Inside: 28" Diam x 45" High

Outside Dimensions: 36" W x 92" H x 49" D

Shipping Dim with Vent & Furn Kit: 48" W x 85" H x 40" D &
48" W x 38" H x 44" D

Ship Weight (Kiln): 670 LBS

Ship Weight (Kiln, Vent & Furn Kit): 860 LBS



FURNITURE KIT FOR JD2945-3

Part Number: H-J-K294/00

Includes: Twelve 25.5" (64.8 cm) half shelves, One post kit with 6 each 1/2", 1", 2", 4", 6", and 8" square posts, and one pair heat resistant gloves.

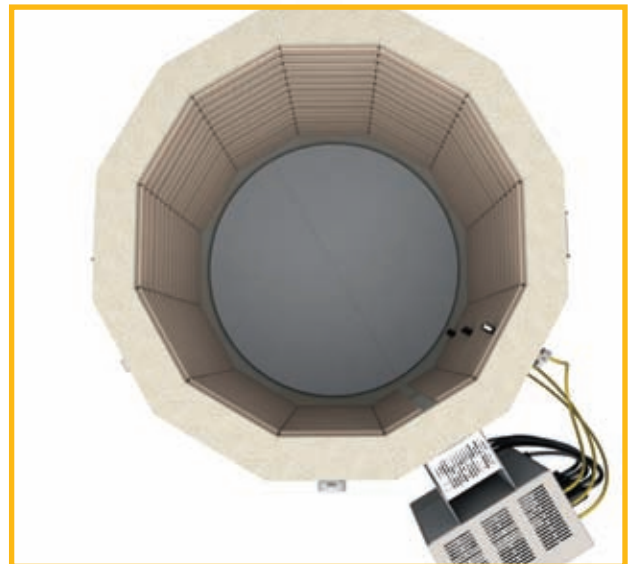

What Makes Jupiter Kilns Built to Last?

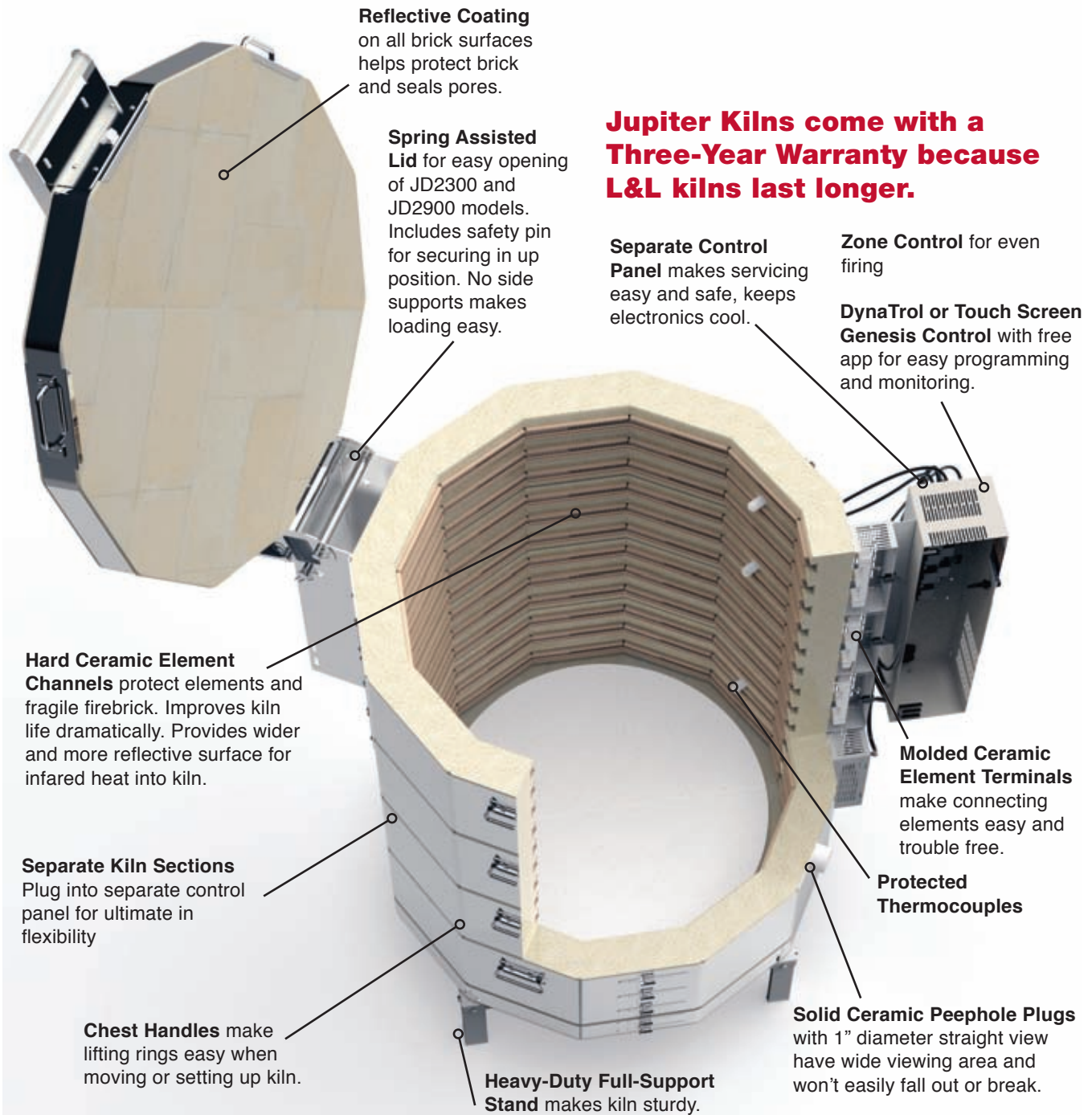

505 Sharptown Road • Swedesboro, NJ 08085
Phone: 856.294.0077 • Fax: 856.294.0070
sales@hotkilns.com • hotkilns.com

KILNS BUILT TO LAST

Bulletin No: JD-0121