

NOTES:

Control Wire:
16 AWG, 105°C
Power Wire:
10 AWG, 150°C

Industrial & commercial applications may require the installation of a LOCKOUT/TAGOUT device to prevent the Kiln from operating during maintenance.

This Kiln is recommended to be wired & connected to an approved U. L. & NEC configured receptacle controlled with a disconnect switch and properly fused according to the KW load specification listed on the Kiln Nameplate. L&L Kiln Mfg., Inc., also recommends fuses rather than circuit breakers to prevent nuisance tripping.



LOOKING INSIDE CONTROL PANEL

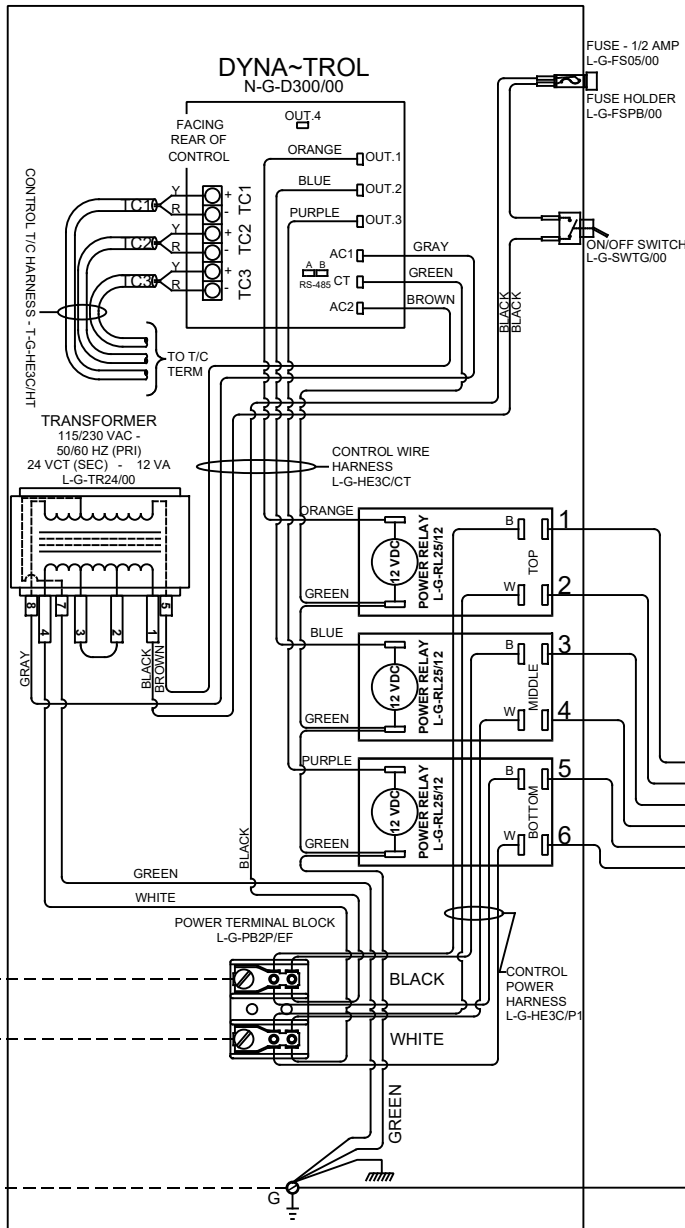

LOOKING AT OUTSIDE OF ELEMENT COVER PANEL

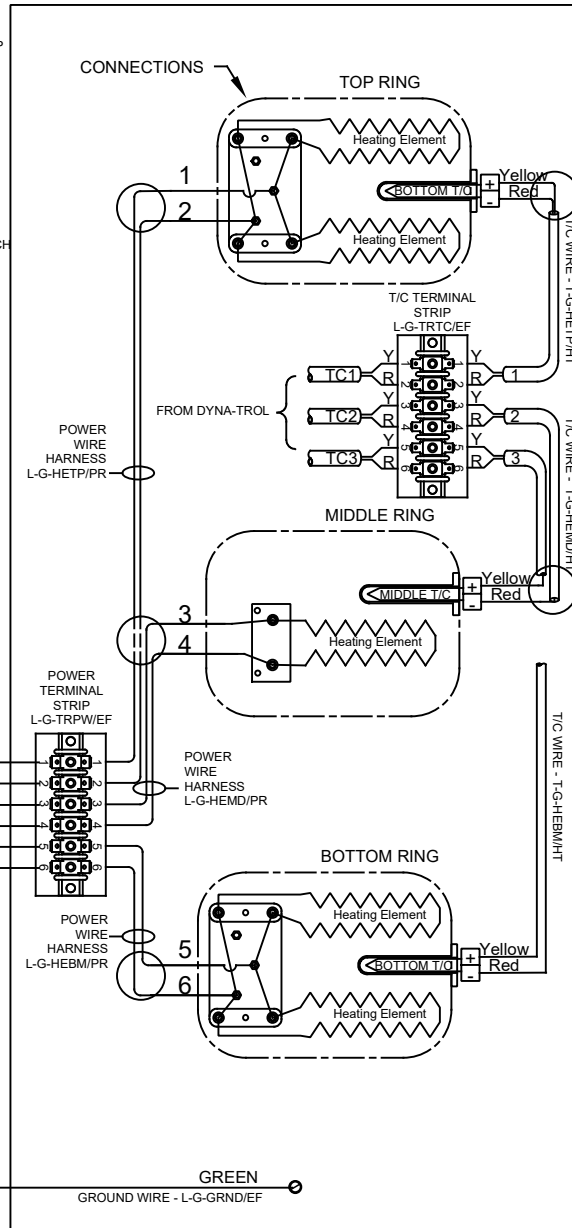

Model e23M-220

VOLTAGE	220 / 1 / 50-60		
WATTS	10,560		
FULL LOAD AMPS	L1	L2	L3
	48.0	48.0	
POWER SUPPLY	FUSE	WIRE	
	60A	6 AWG	
ELEMENTS	QTY	OHMS	
	5	22.1	

SAFETY SWITCH BY CUSTOMER
Connect to
220 Volt, 2 Wire, Single Phase
50 or 60 Cycles.

REV. #	DATE	REVISION DESCRIPTION