

# L&L DAVINCI KILN ASSEMBLY INSTRUCTIONS

## **WHEN YOUR KILN ARRIVES**

Depending on the model and accessories, your kiln will arrive on two or three crated skids. If the skids were damaged in transit, you should either refuse shipment or unpack the kiln in the drivers presence in order to file a damage report with the freight company. Call our office. See *ship-inspect.pdf* in the front of the instruction book. **Inspect for damage!**

***Below is a picture of how your kiln should arrive:***

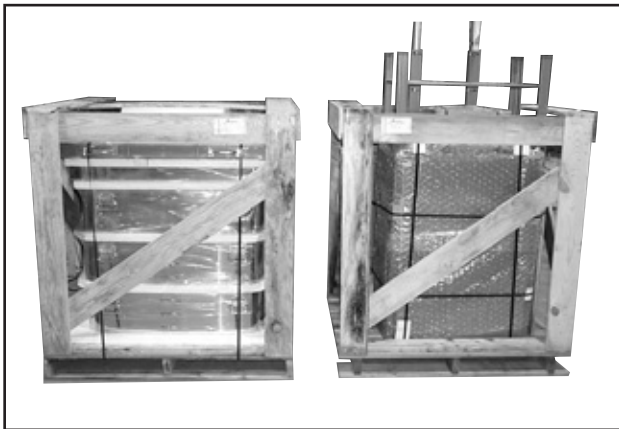

## **UNPACK THE CRATES**

Carefully remove and dispose of the crating boards on the crated skids. One of the crates contains the kiln stand, kiln counterbalance, kiln control panel as well as any additional accessories you may have ordered. The other skid or skids contain the individual kiln sections stacked in reverse order so they can be set up in the proper order, as well as the kiln top or lid, the kiln bottom or floor and the aluminized plate that sits between the floor and the kiln stand.

## **SET UP THE STAND AND BOTTOM**

Remove the kiln stand and place it on the floor in desired location. See *cautions.pdf* in the OPERATION section and *preorder.pdf* in the INSTALLATION section for more detailed information on codes, ventilation requirements, clearances, etc.

Place the flat aluminized plate and the floor of the kiln on top of the kiln stand. Note that the aluminized plate

is packed directly under the kiln floor. This enables you to move both pieces to the kiln stand as one unit. Make sure that the plate and the floor sit flush on the stand. Make certain it is centered properly. If a vent is supplied to be mounted to bottom make sure this is attached now.

***Put the floor on the stand and level:***



**LEVEL THE KILN!** This is important because the Dawson Kiln Sitter is affected by gravity. If the kiln is not properly leveled the Kiln Sitter might be either too reactive or too sluggish. **ALSO IF KILN IS NOT LEVELED THIS COULD LEAD TO THE CRACKING OF THE BOTTOM AND THE TOP**

## **STACK SECTIONS ON BOTTOM**

Notice that each of the two (or more) kiln sections have numbered power cords (referred to as element box jumper cords). The top kiln section will always be # 1. The bottom kiln section will be # 2 on a 2 section kiln, # 3 on a 3 section kiln, etc. Now stack the kiln sections in proper order.

# L&L DAVINCI KILN ASSEMBLY INSTRUCTIONS

**Stack sections on kiln floor in reverse order from the way they are stacked on the packing skid. The top ring on the skid will be the bottom ring on the kiln.**

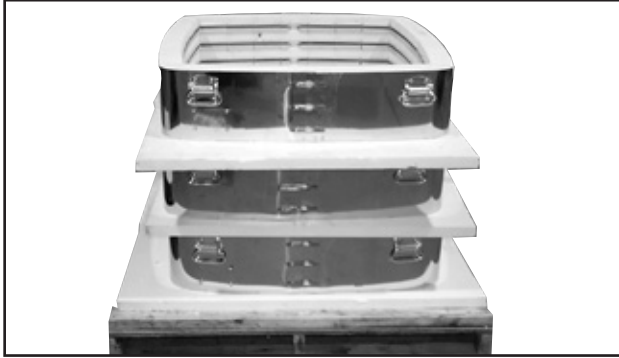

## **KILN DOOR PLACEMENT**

Remove the hinge bar and its hardware and set aside.

Place the kiln door/top squarely on top of the top kiln section. Notice that the door is slightly larger than the kiln section. Space the door as evenly as possible, this will help you later when attaching your counterbalance.

**Kiln Door:**



## **ATTACH COUNTERBALANCE**

Remove the sixteen screws that are in the bottom and third from the bottom kiln sections. (These screws are in the top and bottom sections on a two section kiln). These screws will be used to attach the counterbalance arms to the kiln. Maneuver the counterbalance into position lining the holes in the kiln sections up with the holes in the counterbalance arms. If you can not get the holes to line up you must adjust the stacked kiln sections appropriately. Now replace the sixteen screws.

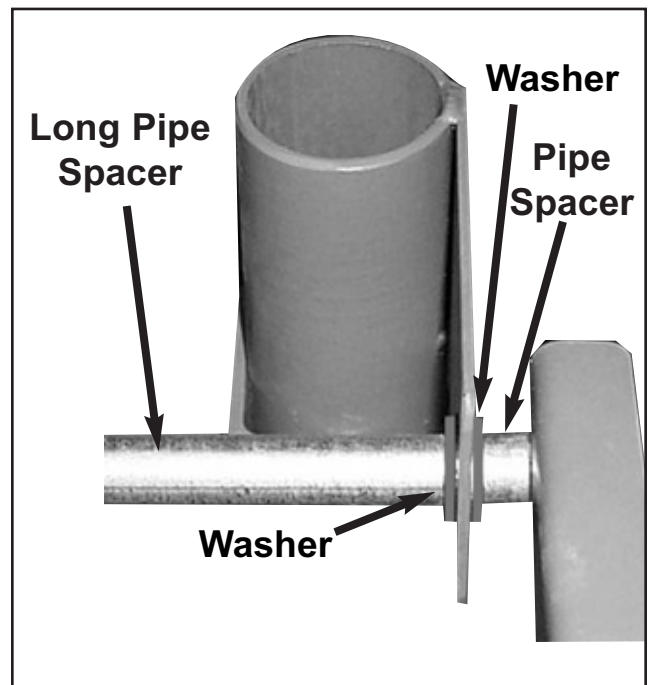
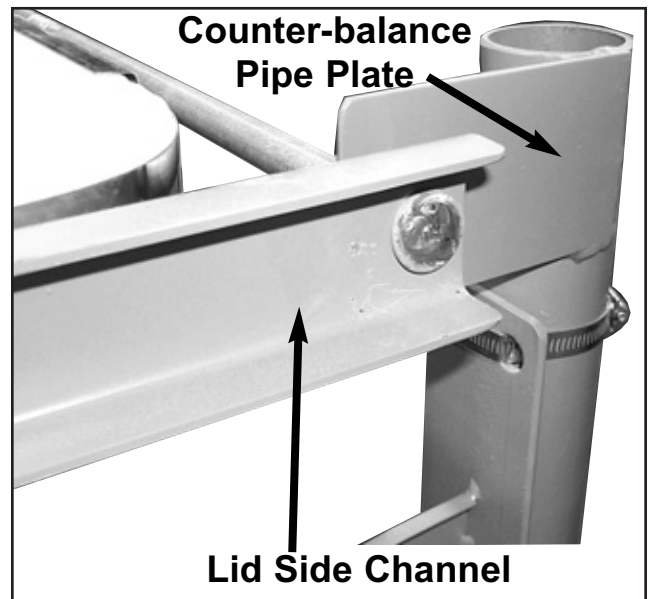

# L&L DAVINCI KILN ASSEMBLY INSTRUCTIONS

**Counterbalance arms screws into the sides of the kiln:**

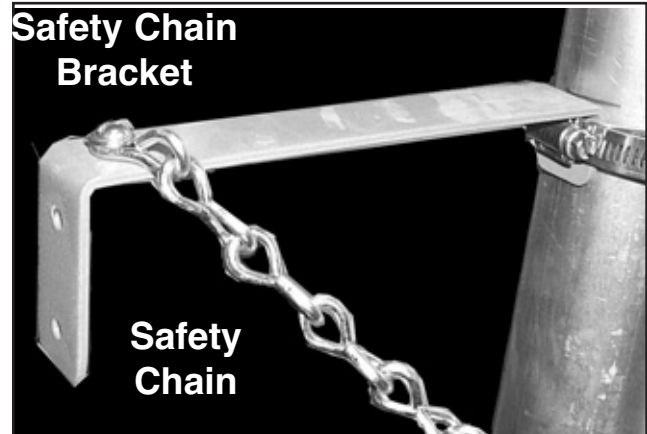

## **ASSEMBLE DOOR AND HINGE**

As gently as possible, position the kiln lid so that the oblong holes in the counter-balance pipe plates line up with the round holes in the lid side channels. The counter-balance pipe is factory set so that the round bar sit at the bottom of the oblong hole of the pipe plate. This is important as it allows the kiln lid to pivot as well as rise as the kiln heats and the brick expands.

## **ATTACH DOOR TO SPRING CABLE**

If necessary, turn the spring tubes so that the opening where the cable comes out at the top of each tube is facing the front of the kiln. Tighten the cable clamps that hold the spring tube to the angle. (These have been loosened for shipping).

If necessary, position the spring tube safety brackets so that they are facing towards the back of the kiln.

Lift the door and attach the safety chains to the eyebolts at each side of the kiln door.

Open the oval connectors and connect the cable from the tubes to the cable adjusters that are already on the eyebolts on the front of the door.

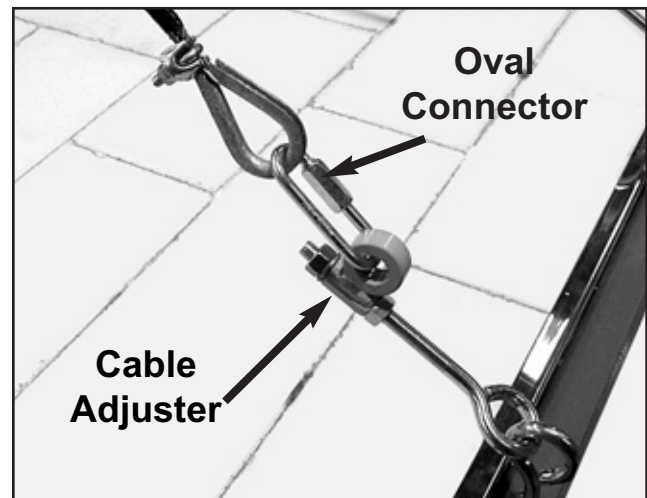

# L&L DAVINCI KILN ASSEMBLY INSTRUCTIONS

## **SET UP CONTROL PANEL**

Set your control panel on the right side of your kiln.

*The gray wire from the dyna-trol plugs into the receptacle that is located on top of the electrical control panel.*



## **INSTALL DYNATROL**

The hand held Dyna-Trol unit hangs on the supplied eyebolt on the control panel or on your wall.

## **ATTACH THERMOCOUPLES**

*Next you will attach the yellow thermocouple lead wires to the thermocouples that are already factory installed on your kiln sections.*

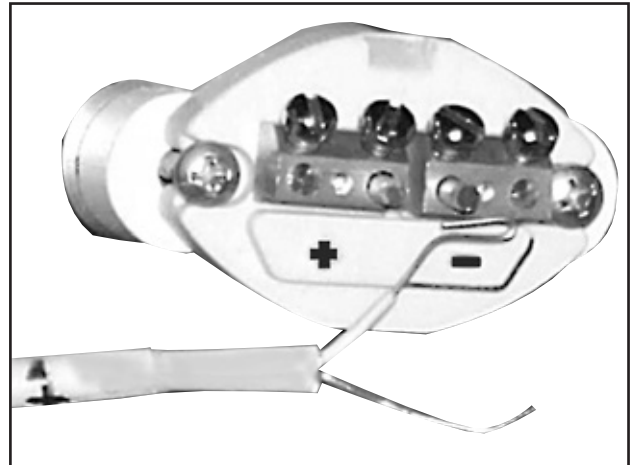

Each of the thermocouple lead wires are numbered to correspond with the location of the thermocouple on the kiln. The number 1 thermocouple lead wire must be attached to the top thermocouple. The number 2 thermocouple wire will attach to the bottom kiln section thermocouple on a two section kiln or the middle kiln section thermocouple on a three or more section kiln. If not done correctly, your kiln will not operate properly.

To attach the thermocouple lead wire, simply screw the red wire to the negative terminal of the thermocouple and the yellow wire to the positive terminal of the thermocouple. (You can see a “-” mark and a “+” mark embedded in the ceramic terminal).

Before firing your kiln, make sure the thermocouple lead wires are not touching the kiln. If these wires burn, your control will not operate properly.

# L&L DAVINCI KILN ASSEMBLY INSTRUCTIONS

## **PLUG IN KILN SECTIONS**

Now you can plug your element box jumper cords into the appropriate receptacles. Start at the top section. The element box jumper cord should be numbered 1, and plugged into the #1 receptacle. The TC lead wire on the top section of the kiln must be numbered 1. Repeat these steps for the remaining kiln sections.

***Jumper cords are plugged into the panel.***



## **INSTALL DAWSON KILN SITTER**

See the separate sheet on setting up the Dawson kiln sitter (*dawson-setup.pdf*) in the ASSEMBLY section. Check Dawson Kiln Sitter for adjustment. Read Dawson Kiln Sitter manual for instructions on this process.

## **BELL-LIFT KILN OPTION**

The supplement for assembly of the Bell-Lift option is a CD Rom with photographs.

## **FINAL STEPS**

### **INSTALL VENT**

If your kiln is equipped with a vent fan exhaust tubing to outside. See separate vent instructions.

### **HOOK UP ELECTRIC POWER**

See the wiring diagram for electrical specifications. All Davinci Kilns are direct wired. You are now ready for your test firing. See the main instruction manual

(*davinci-instruct.pdf*). BE SURE TO READ THE INSTRUCTIONS.

### **READ CAUTIONS**

DO NOT PROCEED WITHOUT READING AND UNDERSTANDING THE CAUTIONS IN THE OPERATIONS SECTION.

### **VACUUM KILN**

Vacuum the kiln before using it (with power disconnected from kiln).

### **FIRST TEST FIRING**

You are now ready for your test firing: See the main instructions in the OPERATION section.