

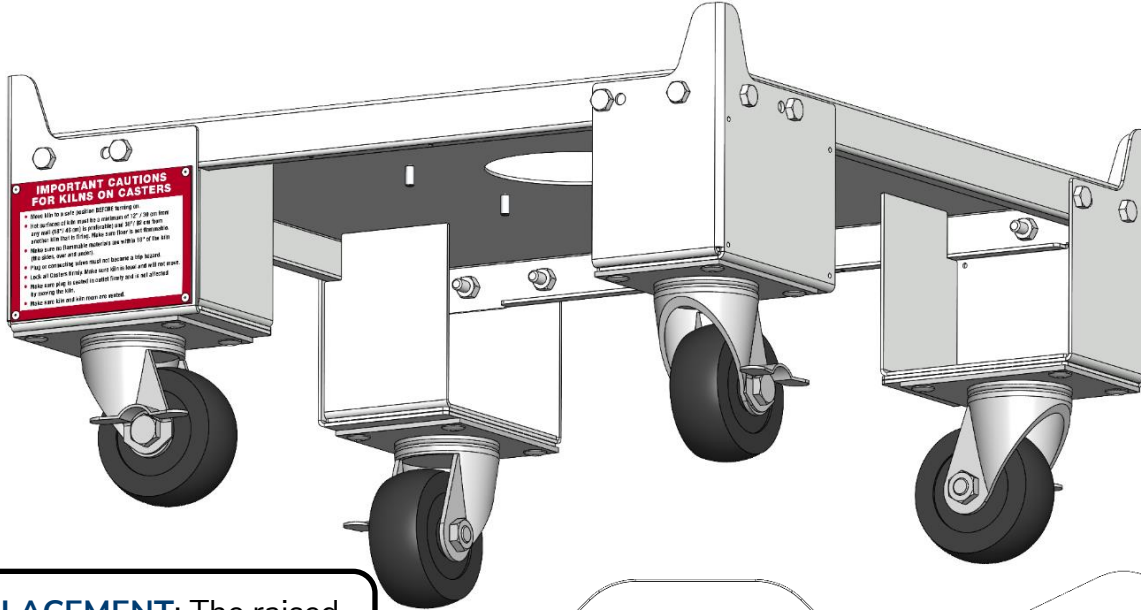

Rolling Stand Assembly Instructions

PARTS: $\frac{1}{4}$ " flange-hex-head bolts(16), $\frac{1}{4}$ " flange-hex nuts(16), leg-caster assemblies(4).

ASSEMBLY: Line legs up with corner holes as shown. Insert 4 bolts per leg with the nuts on the inside of the stand – **ensure bolts are tight using a wrench**. Once assembled, lock the casters by applying pressure to the levers on the wheels before placing your kiln on top.



KILN PLACEMENT: The raised corners on the legs rise above the stand to prevent the kiln from shifting while rolling the kiln around, and to ensure the vent holes remain centered over the vent-collection-box underneath the stand (when the L&L Vent-Sure downdraft system is installed).

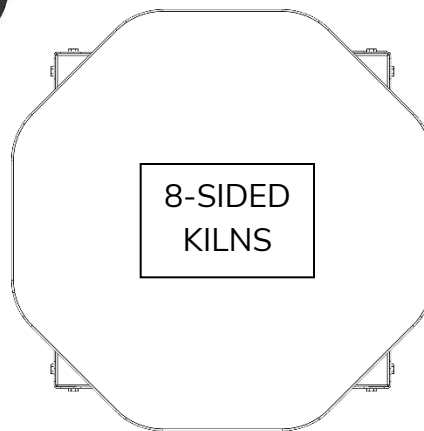

8-SIDED
KILNS

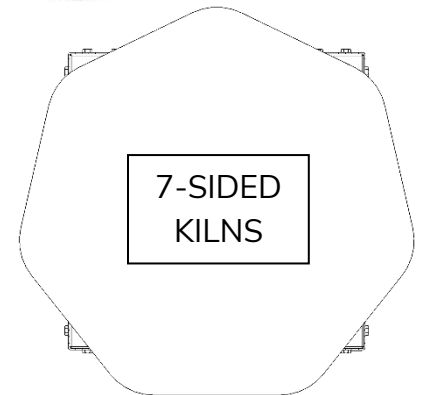

7-SIDED
KILNS

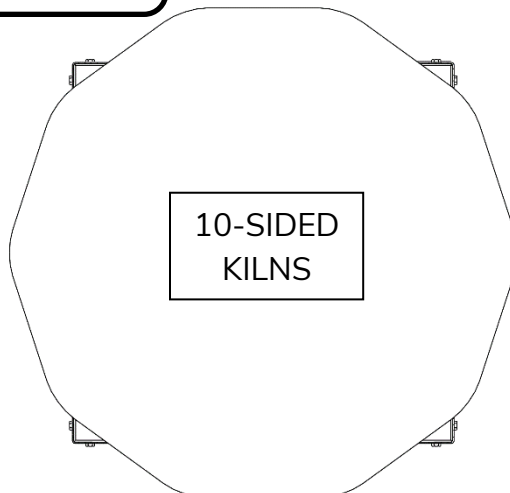

10-SIDED
KILNS

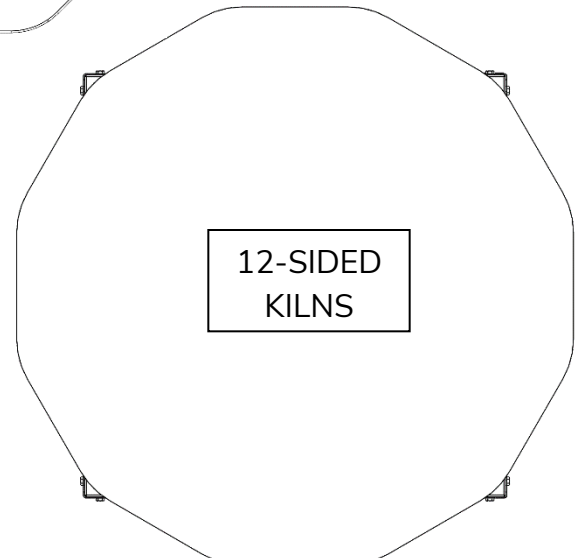

12-SIDED
KILNS



Rolling Stand Assembly Instructions

CAUTION: Read the cautions on the red caution plate and note the following:

- Do not remove the included casters – top of stand must be at least 8” from the ground
- Rolling Stand is not intended for rolling while kiln is loaded
- Do not attempt to roll down or up an incline or over rough ground

EXAMPLE OF A FULLY ASSEMBLED e18M-3 KILN AND STAND:

