

- WALL/KILN SPACING:** 12" [30.5cm] SPACING BETWEEN SIDES OF KILN AND WALLS OR OTHER OBJECTS. 18" [45.7cm] IS RECOMMENDED. LEAVE AT LEAST 18" [45.7cm] BETWEEN TWO KILNS.
- AMBIENT VENTILATION:** SEE CHART TO RIGHT FOR RATINGS. TO CALCULATE REQUIREMENTS, SEE hotkilns.com/calculate-kiln-room-ventilation.
- KILN VENTILATION:** L&L VENT-SURE KILN VENT RECOMMENDED FOR SAFETY AND LONGER ELEMENT LIFE. OPTIONAL CONTROL ALLOWS VENT TO BE TURNED ON AND OFF WITH CONTROL.

- OTHER INFO:** REFER TO INSTALLATION INSTRUCTIONS AND CAUTIONS INSTRUCTIONS FOR OTHER REQUIREMENTS AND SAFETY INFORMATION. REFER TO WIRING DIAGRAM FOR ELECTRICAL HOOKUP INFORMATION.
- MAX LOAD WEIGHT:** SEE hotkilns.com/load-weight.
- WEIGHT OF KILN:** 915 LBS, 415 KG

BTUS/ KILOJOULES PER HOUR NEEDED TO BE VENTED WITH AMBIENT ROOM VENTILATION (THIS IS IN ADDITION TO KILN VENTING):

AT TEMP F	BTUS	AT TEMP C	KILOJOULES
1800F	22293	980C	23521
2000F	26065	1095C	27500
2232F	30779	1222C	32474
2350F	33315	1285C	35149

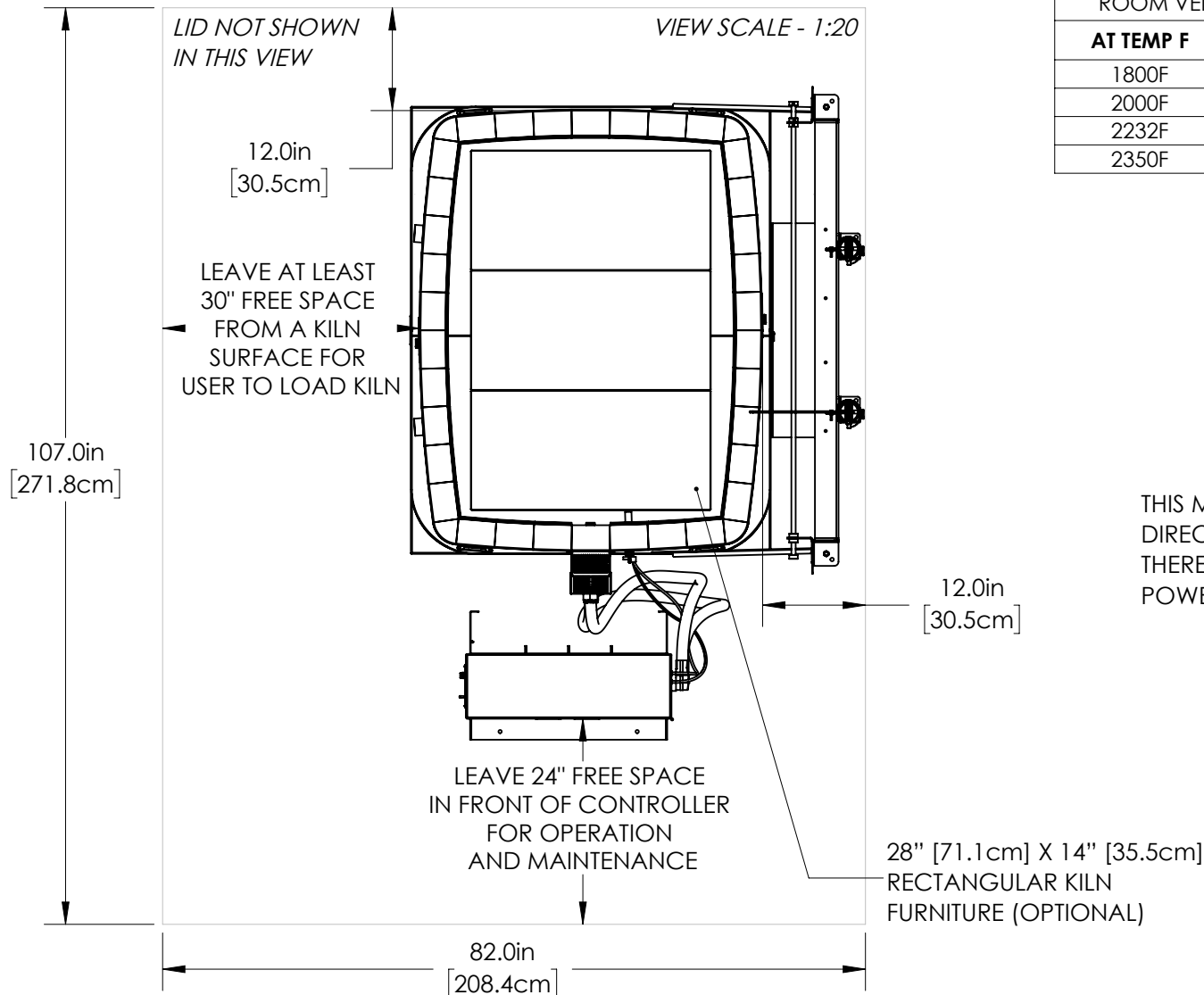

T34 MODELS REQUIRE TWO-PERSON LIFT DUE TO WEIGHT OF LID

THIS MODEL IS DIRECT WIRED. THERE IS NO POWER CORD.

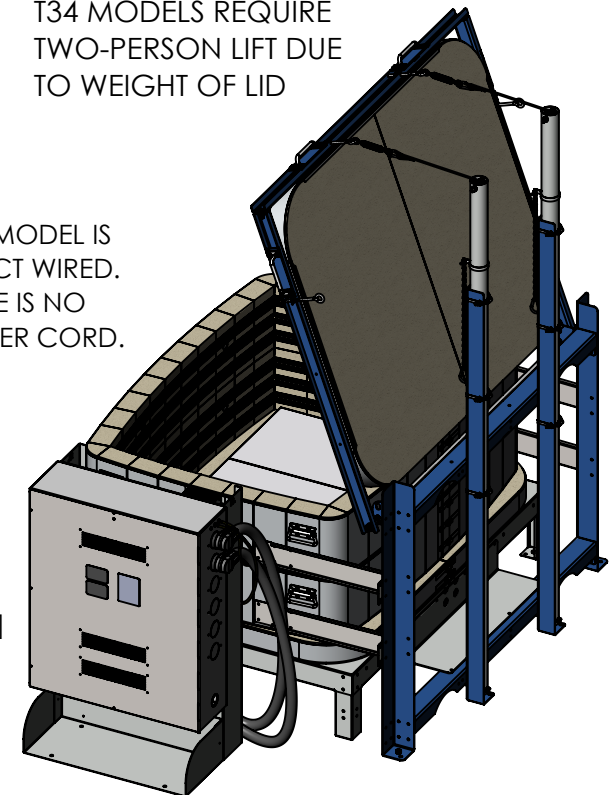

LID NOT SHOWN
IN THIS VIEW

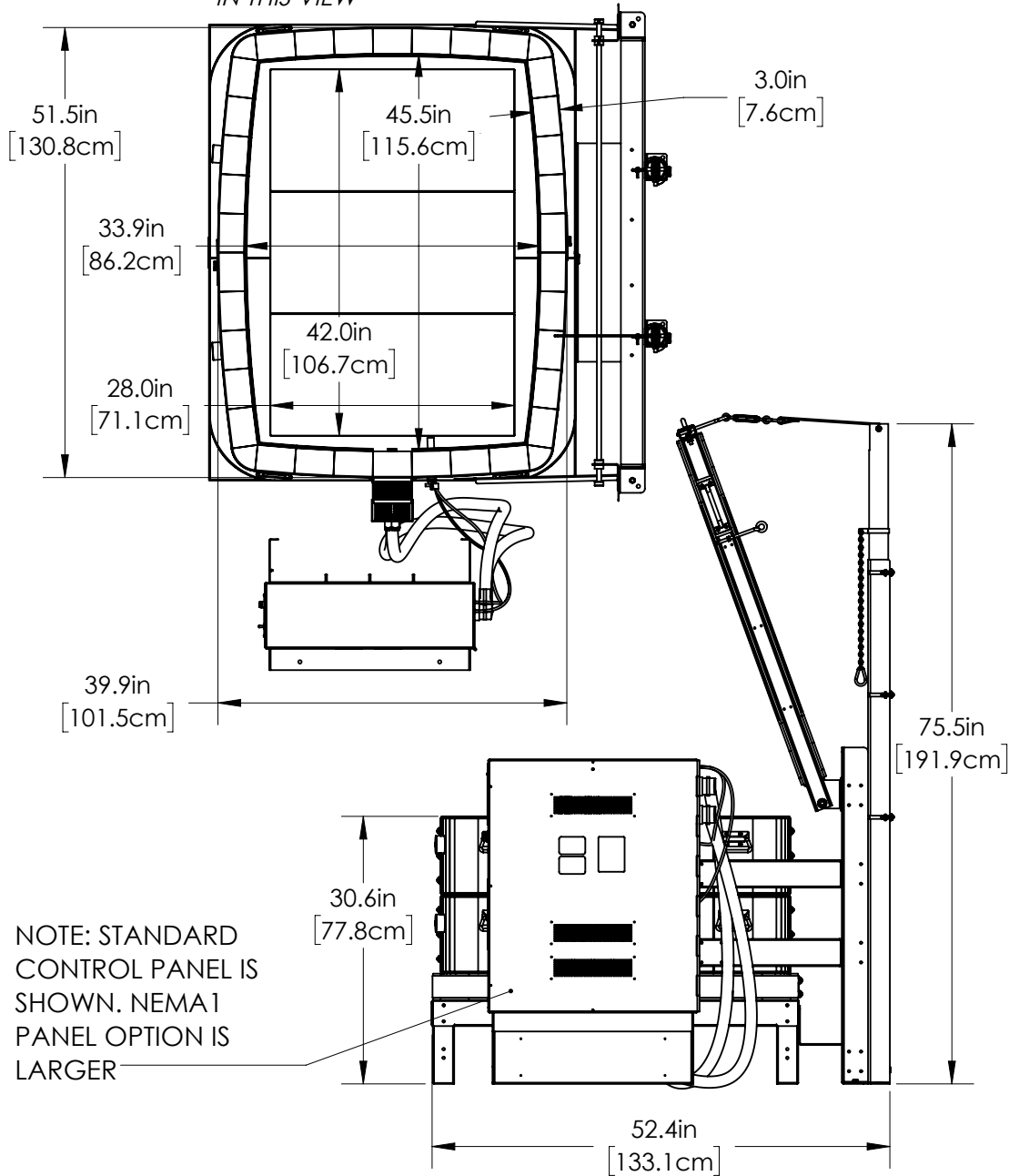

NOTE: STANDARD
CONTROL PANEL IS
SHOWN. NEMA 1
PANEL OPTION IS
LARGER

EXPANDABILITY: THIS MODEL CAN BE EXPANDED
TO A T3427 BY ADDING ONE SECTION AND
ADDING CORRESPONDING CIRCUITS IN THE
CONTROL PANEL.

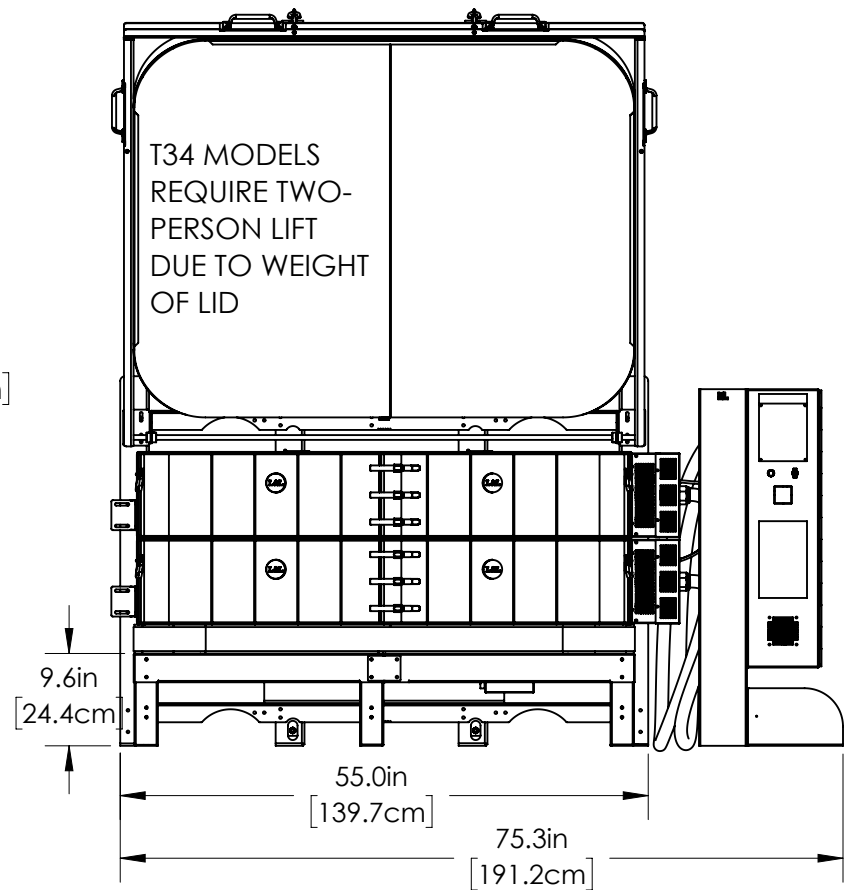

MADE FROM NEW	DRAWN BY SJL	DATE 04/15/20	SCALE 1:20	TITLE TB3418-D (3" BRICK) GENERAL DIMENSIONS
------------------	-----------------	------------------	---------------	---



505 SHARPTOWN RD
SWEDESBORO NJ 08085
PH: (856) 294-0077
FAX: (856) 294-0070

REV 0	SHEET OF 2/3	DRAWING NO. 300-000-60-2
----------	-----------------	-----------------------------

5

4

3

2

1

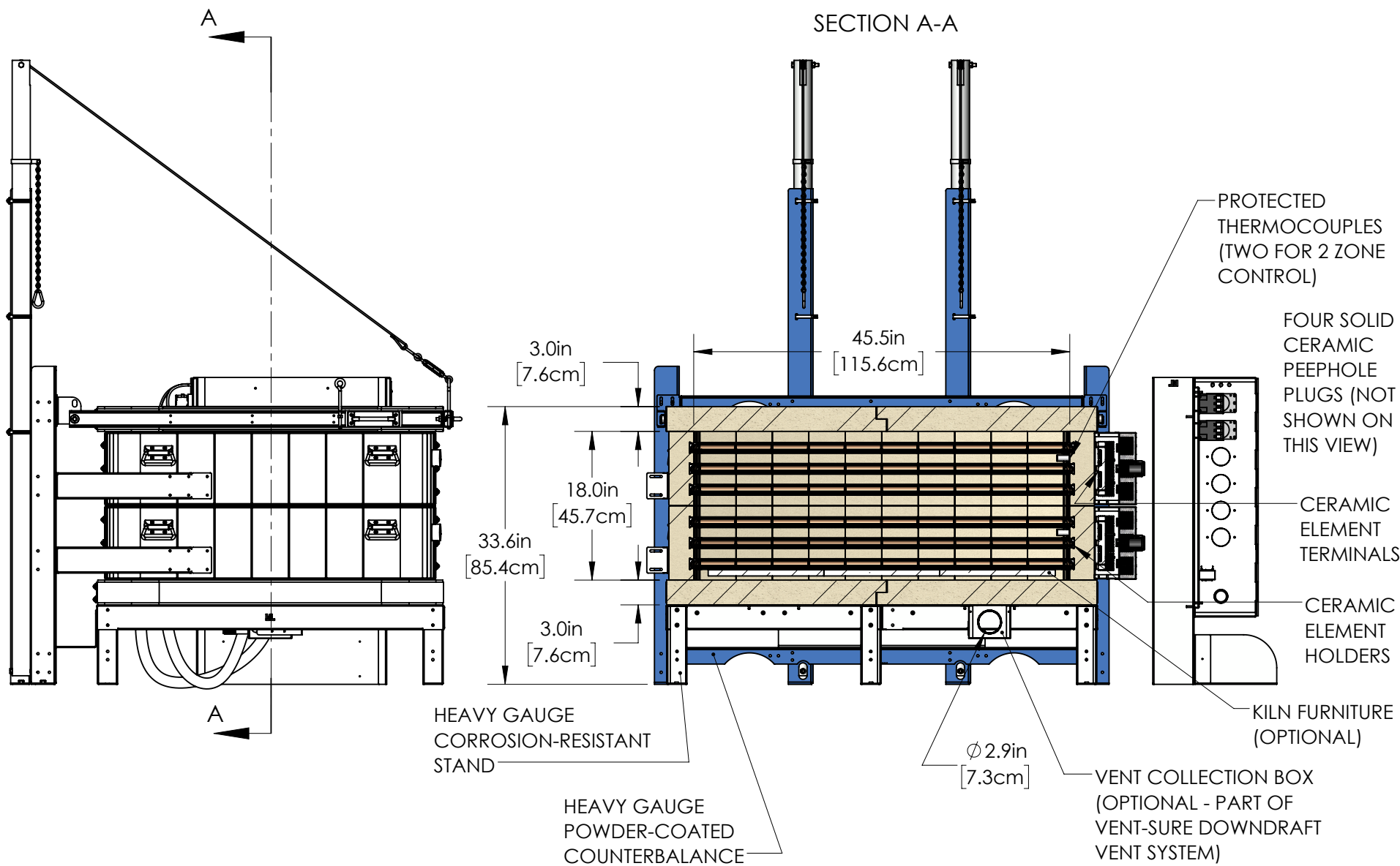

OPTIONAL FURNITURE KIT: (6) 28" [71.1cm] X 14" [35.5cm] RECTANGULAR SHELVES, (12) EACH 1/2", 1", 2", 4", 6" & 8" SQUARE POSTS

MADE FROM NEW	DRAWN BY S JL	DATE 04/15/20	SCALE 1:17	TITLE TB3418-D (3" BRICK) DAVINCI GENERAL DIMENSIONS	LKilns hotkilns.com	505 SHARPTOWN RD SWEDESBORO NJ 08085 PH: (856) 294-0077 FAX: (856) 294-0070	REV 0	SHEET OF 3/3	DRAWING NO. 300-000-60-2
------------------	------------------	------------------	---------------	---	-------------------------------	--	-----------------	-----------------	-----------------------------