

- WALL/KILN SPACING:** 12" [30.5cm] SPACING BETWEEN SIDES OF KILN AND WALLS OR OTHER OBJECTS. 18" [45.7cm] IS RECOMMENDED. LEAVE AT LEAST 18" [45.7cm] BETWEEN TWO KILNS.
- AMBIENT VENTILATION:** SEE CHART TO RIGHT FOR RATINGS. TO CALCULATE REQUIREMENTS, SEE hotkilns.com/calculate-kiln-room-ventilation.
- KILN VENTILATION:** L&L VENT-SURE KILN VENT RECOMMENDED FOR SAFETY AND LONGER ELEMENT LIFE. OPTIONAL CONTROL ALLOWS VENT TO BE TURNED ON AND OFF WITH CONTROL.

- OTHER INFO:** REFER TO INSTALLATION INSTRUCTIONS AND CAUTIONS INSTRUCTIONS FOR OTHER REQUIREMENTS AND SAFETY INFORMATION. REFER TO WIRING DIAGRAM FOR ELECTRICAL HOOKUP INFORMATION.
- MAX LOAD WEIGHT:** SEE hotkilns.com/load-weight.
- WEIGHT OF KILN:** 610 LBS, 277 KG

BTUS/ KILOJOULES PER HOUR NEEDED TO BE VENTED WITH AMBIENT ROOM VENTILATION (THIS IS IN ADDITION TO KILN VENTING):

AT TEMP F	BTUS	AT TEMP C	KILOJOULES
1800F	13899	980C	14665
2000F	16250	1095C	17145
2232F	19189	1222C	20245
2350F	20769	1285C	21913

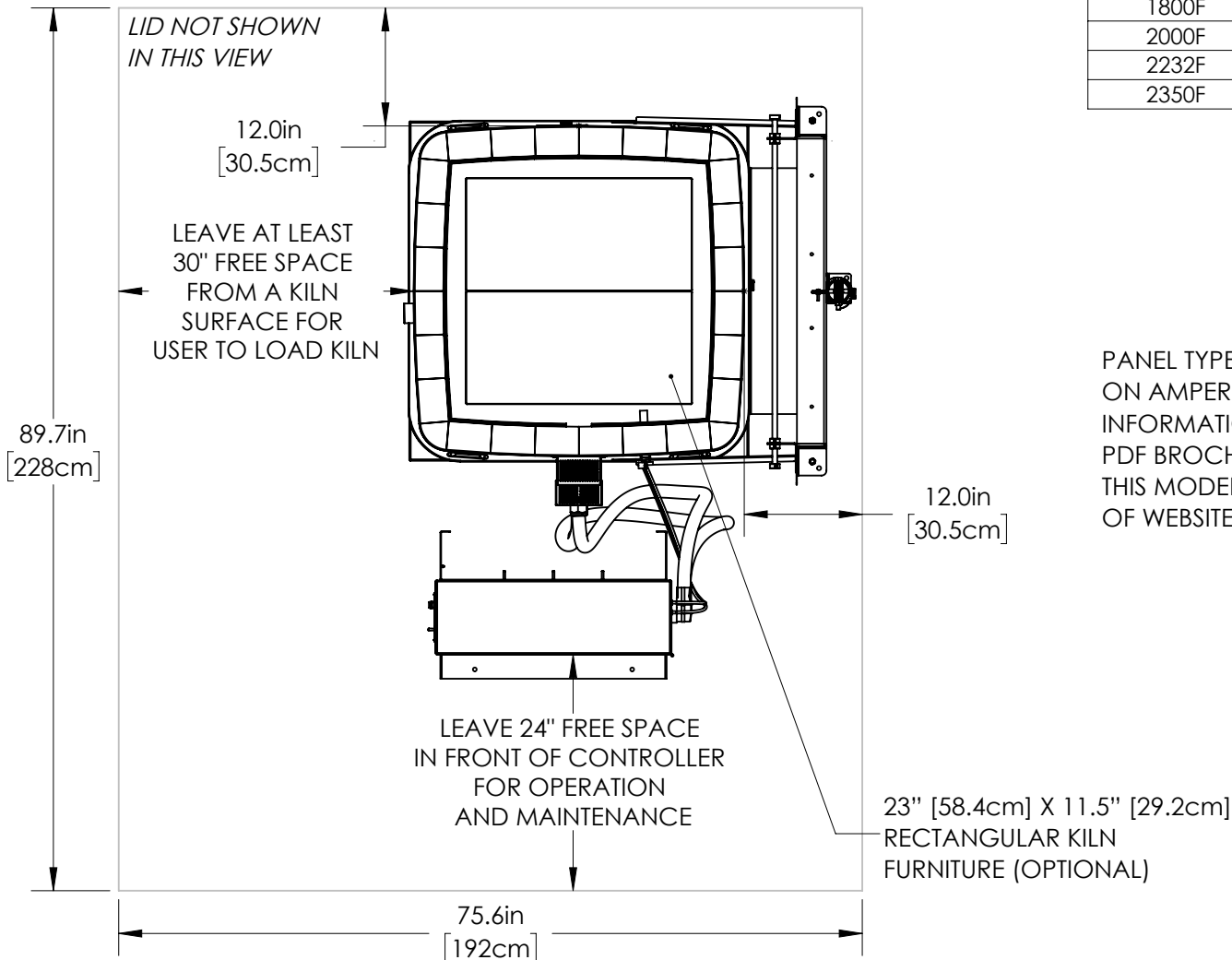

THIS MODEL IS DIRECT WIRED. THERE IS NO POWER CORD.

PANEL TYPE DEPENDS ON AMPERAGE. FOR INFORMATION, SEE PDF BROCHURE ON THIS MODEL'S PAGE OF WEBSITE.

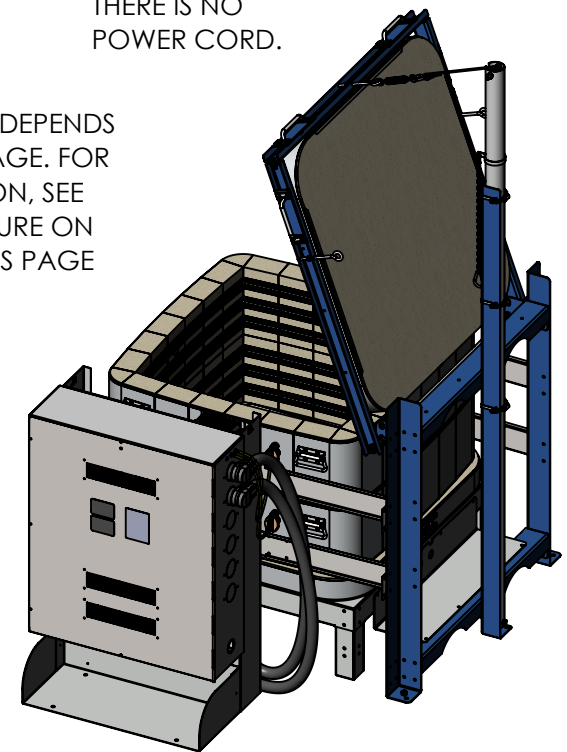

LID NOT SHOWN
IN THIS VIEW

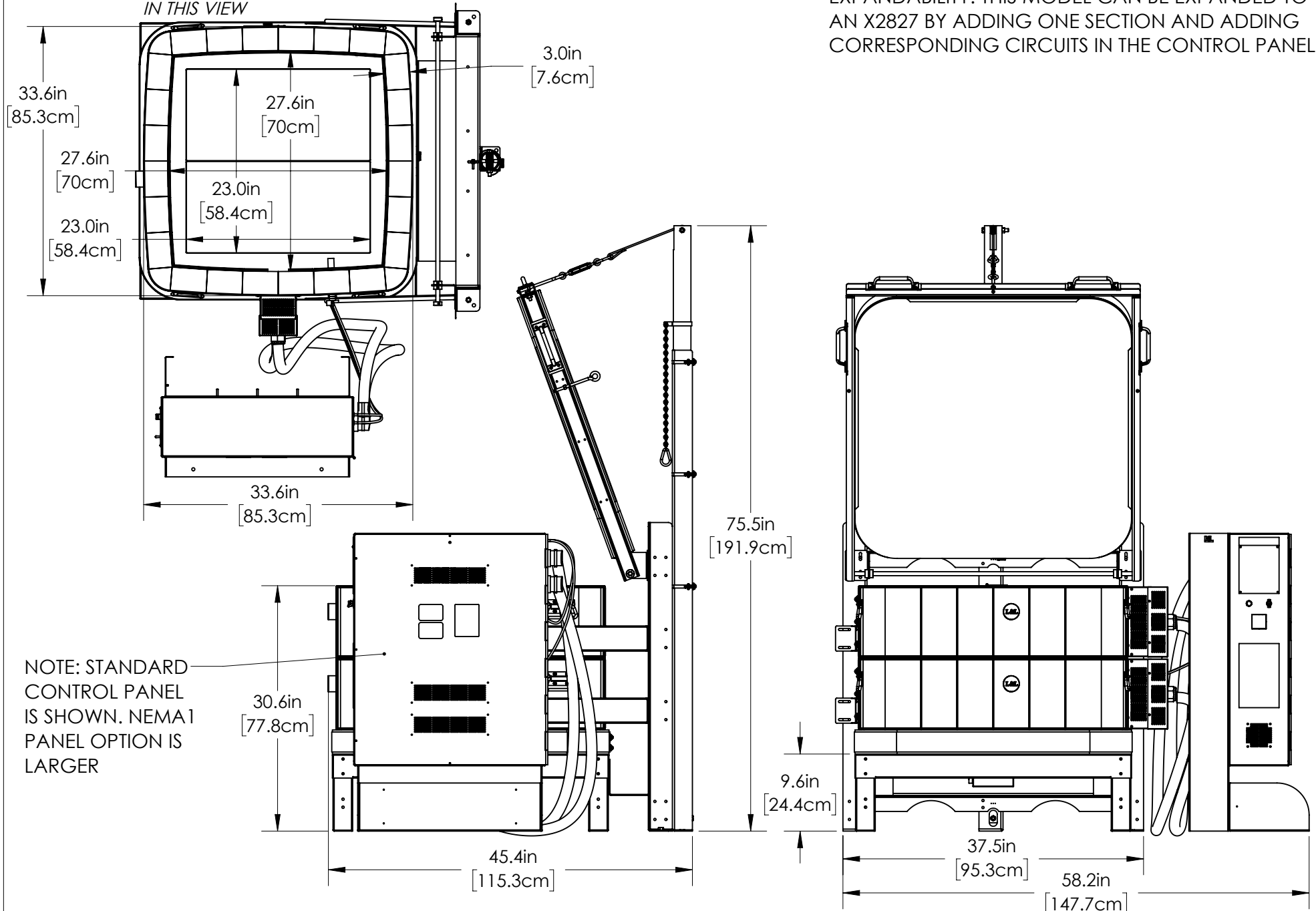

EXPANDABILITY: THIS MODEL CAN BE EXPANDED TO AN X2827 BY ADDING ONE SECTION AND ADDING CORRESPONDING CIRCUITS IN THE CONTROL PANEL.

NOTE: STANDARD CONTROL PANEL IS SHOWN. NEMA 1 PANEL OPTION IS LARGER

DRAWN BY S JL	DATE 04/15/20	SCALE 1:16	TITLE XB2818-D (3" BRICK) DAVINCI GENERAL DIMENSIONS		505 SHARPTOWN RD SWEDESBORO NJ 08085 PH: (856) 294-0077 FAX: (856) 294-0070	REV 0	SHEET OF 2/3	DRAWING NO. 300-000-30-2
------------------	------------------	---------------	---	---	--	----------	-----------------	-----------------------------

5

4

3

2

1

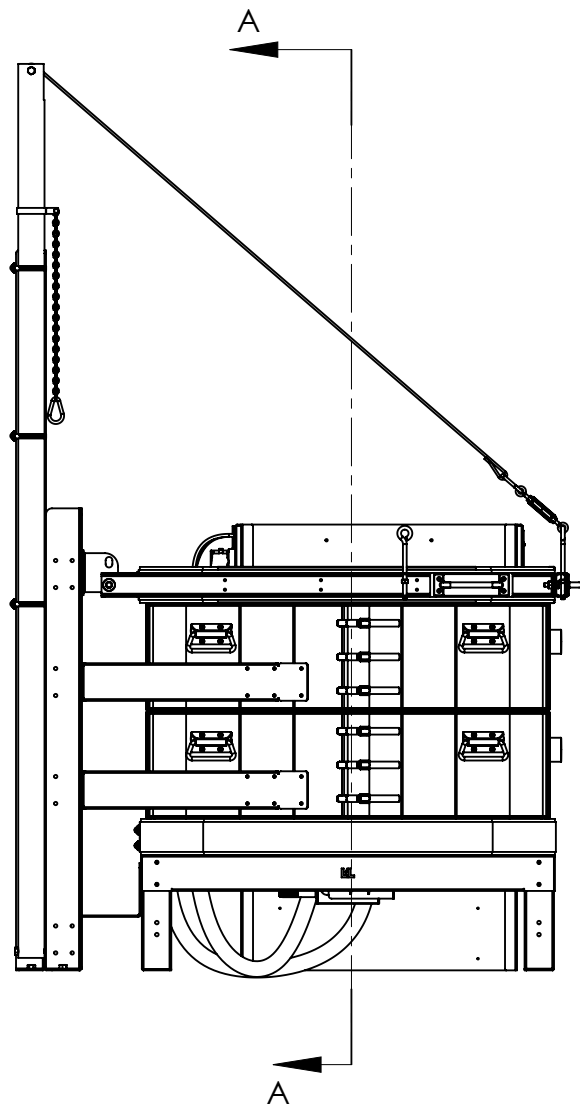

SECTION A-A

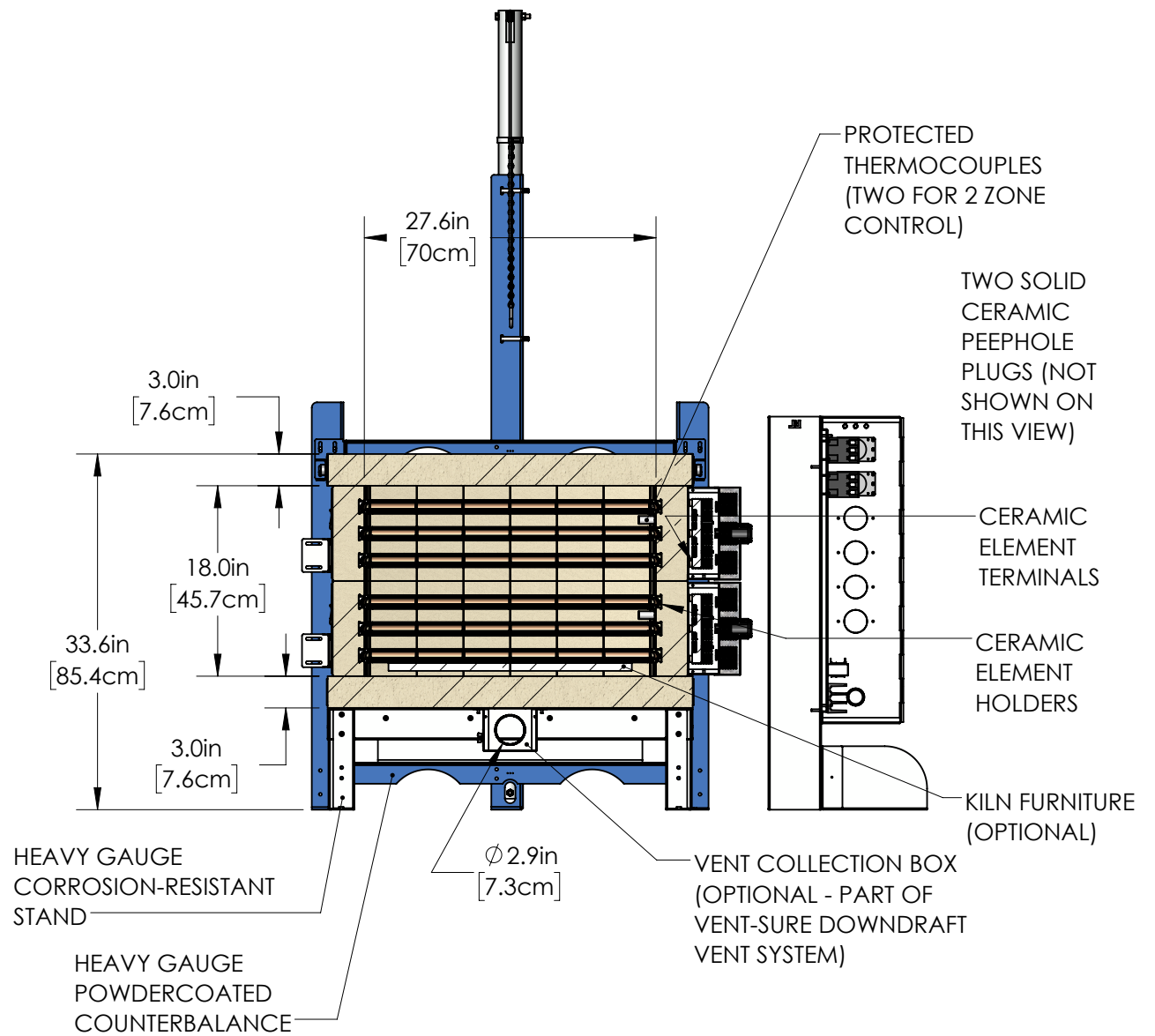

OPTIONAL FURNITURE KIT: (4) 23" [58.4cm] X 11.5" [29.2cm] RECTANGULAR SHELVES, (6) EACH 1/2", 1", 2", 4", 6" & 8" SQUARE POSTS

DRAWN BY SJL	DATE 04/15/20	SCALE 1:16	TITLE XB2818-D (3" BRICK) DAVINCI GENERAL DIMENSIONS		505 SHARPTOWN RD SWEDESBORO NJ 08085 PH: (856) 294-0077 FAX: (856) 294-0070	REV 0	SHEET OF 3/3	DRAWING NO. 300-000-30-2
-----------------	------------------	---------------	---	---	--	----------	-----------------	-----------------------------